

# **EUCHNER**

## **Operating instructions**

**Non-Contact Safety System  
CES-AZ-UES-... (Multicode)**

**EN**

## Contents

<b>1.</b>	<b>About this document</b> .....	<b>4</b>
1.1.	Scope.....	4
1.2.	Target group .....	4
1.3.	Key to symbols.....	4
1.4.	Supplementary documents .....	4
<b>2.</b>	<b>Correct use</b> .....	<b>5</b>
<b>3.</b>	<b>Description of the safety function</b> .....	<b>7</b>
<b>4.</b>	<b>Exclusion of liability and warranty</b> .....	<b>8</b>
<b>5.</b>	<b>General safety precautions</b> .....	<b>8</b>
<b>6.</b>	<b>Function</b> .....	<b>9</b>
6.1.	Block diagrams of CES-AZ-UES-.....	10
<b>7.</b>	<b>Mounting</b> .....	<b>11</b>
<b>8.</b>	<b>Electrical connection</b> .....	<b>12</b>
8.1.	Notes about $\text{UL}^{\text{®}}$ .....	12
8.2.	Safety in case of faults.....	12
8.3.	Fusing of the power supply and the safety contacts.....	12
8.4.	Connection example for CES-AZ-UES-01B .....	13
8.5.	Connection example for CES-AZ-UES-02B .....	14
8.6.	Connection example for CES-AZ-UES-04B .....	15
<b>9.</b>	<b>Setup</b> .....	<b>16</b>
9.1.	LED indicators .....	16
9.2.	Parameter setting.....	16
9.2.1.	Changing the configuration .....	17
9.3.	Functional check.....	18
9.3.1.	Self-test with test input TST .....	18
<b>10.</b>	<b>System status table</b> .....	<b>19</b>
<b>11.</b>	<b>Technical data</b> .....	<b>20</b>
11.1.	Evaluation unit CES-AZ-UES-01B.....	20
11.2.	Evaluation unit CES-AZ-UES-02B.....	22
11.3.	Evaluation unit CES-AZ-UES-04B.....	24
11.4.	Read head CESA-LNN.....	26
11.5.	Read head CESA-LSP.....	28
11.6.	Read head CESA-LNA.....	30
11.7.	Read head CESA-LNA-SC .....	32
11.8.	Read head CESA-LCA.....	34

11.9.	Read head CES-A-LQA-SC .....	36
11.10.	Read head CES-A-LMN-SC.....	38
11.11.	Actuator CES-A-BBN.....	40
11.12.	Actuator CES-A-BSP .....	41
11.13.	Actuator CES-A-BDN-06 .....	42
11.14.	Actuator CES-A-BBA/CES-A-BCA.....	43
11.15.	Actuator CES-A-BQA.....	44
11.16.	Actuator CES-A-BDA-20 .....	45
11.17.	Actuator CES-A-BDA-18 .....	46
11.18.	Actuator CES-A-BMB .....	47
<b>12.</b>	<b>Ordering information and accessories .....</b>	<b>48</b>
<b>13.</b>	<b>Inspection and service .....</b>	<b>48</b>
<b>14.</b>	<b>Service .....</b>	<b>48</b>
<b>15.</b>	<b>Declaration of conformity .....</b>	<b>49</b>

## 1. About this document

### 1.1. Scope

This document is valid for





- Non-Contact Safety System *CES-AZ-UES-01B*, evaluation unit for 1 read head (order no. 105139)
- Non-Contact Safety System *CES-AZ-UES-02B*, evaluation unit for 2 read heads (order no. 105140)
- Non-Contact Safety System *CES-AZ-UES-04B*, evaluation unit for 4 read heads (order no. 105149)

These operating instructions, the document *Safety information* and any enclosed data sheet form the complete user information for your device.

### 1.2. Target group



Design engineers and installation planners for safety devices on machines, as well as setup and servicing staff possessing special expertise in handling safety components.

### 1.3. Key to symbols

Symbol/depiction	Meaning
	Printed document
	Document is available for download at <a href="http://www.euchner.com">www.euchner.com</a>
 <b>DANGER WARNING CAUTION</b>	<b>Signal word:</b> <b>DANGER</b> <b>WARNING</b> <b>CAUTION</b> <b>Consequence if not observed:</b> Death or severe injuries Possibly death or severe injuries Possibly minor injuries
 <b>NOTICE Important!</b>	<b>Signal word:</b> <b>NOTICE</b> <b>Important!</b> Malfunction or device damage possible Important information
<b>Tip</b>	Useful information

### 1.4. Supplementary documents

The overall documentation for this device consists of the following documents:

Document title (document number)	Contents	
Safety information (2525460)	Basic safety information	
Operating instructions (2105274)	(this document)	

	<b>Important!</b> Always read all documents to gain a complete overview of safe installation, setup and use of the device. The documents can be downloaded from <a href="http://www.euchner.com">www.euchner.com</a> . For this purpose enter the doc. no. in the search box.
---	--

## 2. Correct use

Evaluation units of the series CES-AZ are used to evaluate safety-related signals from EUCHNER read heads. Depending on the read heads used, the system can form an interlocking device with or without guard locking. The system meets the requirements according to EN IEC 60947-5-3.

### **The following applies in combination with a CES or CEM read head:**

The system consists of evaluation unit with multicode evaluation, read head and actuator. It forms an interlocking device with low coding level (type 4).

In combination with a movable guard and the machine control, this system prevents dangerous machine functions from occurring while the guard is open. A stop command is triggered if the guard is opened during the dangerous machine function.

This means:

- Starting commands that cause a dangerous machine function must become active only when the guard is closed.
- Opening the guard triggers a stop command.
- Closing a guard must not cause automatic starting of a dangerous machine function. A separate start command must be issued. For exceptions, refer to EN 12100 or relevant C-standards.

### **The following applies in combination with a CET read head:**

The system comprising evaluation unit, read head with guard locking and actuator forms an interlocking device with guard locking featuring a low coding level (type 4).

In combination with a movable guard and the machine control, this system prevents the guard from being opened while a dangerous machine function is being performed.

This means:

- Starting commands that cause a dangerous machine function must become active only when the guard is closed and locked.
- The guard locking must not be unlocked until the dangerous machine function has ended.

Closing and locking a guard must not cause automatic starting of a dangerous machine function. A separate start command must be issued. For exceptions, refer to EN 12100 or relevant C-standards.

Before use, a risk assessment must be performed on the machine, e.g. according to the following standards:

- EN ISO 13849-1
- EN ISO 12100
- IEC 62061

Correct use includes observing the relevant requirements for installation and operation, e.g. according to the following standards:

- EN ISO 13849-1
- EN ISO 14119
- EN 60204-1

The following components can be connected to the evaluation unit CES-AZ-UES...:

- CES read heads
- CEM read heads
- CET read heads
- CKS key adapter

For further information, refer to the operating instructions of the corresponding component and to *Table 1: Possible combinations for CES components on page 6*.



**Important!**

- › The user is responsible for the proper integration of the device into a safe overall system. For this purpose, the overall system must be validated, e.g. in accordance with EN ISO 13849-2.
- › Correct use requires observing the permissible operating parameters (see technical data).
- › If a data sheet is included with the product, the information on the data sheet applies.
- › It is only allowed to use components that are permissible in accordance with the table below.

Table 1: Possible combinations for CES components

Evaluation unit	Read head	Actuator												
		CES-A-BSP-104970 104970	CES-A-BBN-106600 106600	CES-A-BDN-06-104730 104730	CES-A-BBA 071840	CES-A-BCA 088786	CES-A-BQA 098108	CES-A-BDA-20 084720	CES-A-BDA-18 156935	CES-A-BMB 077791	CEM-A-BE05 094805	CEM-A-BH10 095175	CET-A-BWK-50X 096327	CKS-A-BK1... CKS key
CES-AZ-UES-01B 105139 CES-AZ-UES-02B 105140 CES-AZ-UES-04B 105141	CES-A-LSP-... All items	20												
	CES-A-LNN-... All items		15	19										
	CES-A-LCA-... All items				15	15		16	16					
	CES-A-LNA-... All items				15	15		16	16					
	CES-A-LQA-SC 095650				15	15	23							
	CES-A-LMN-SC 077790				8	8		9	9	5				
	CEM-A-LE05K-S2 094800													
	CEM-A-LE05R-S2 095792													
	CEM-A-LH10K-S3 095170													
	CEM-A-LH10R-S3 095793													
CET1-AX-LRA-... 095735														
CET1-AX-LDA-... 100399														
CKS-A-L1B-... 113130													●	

<b>Key to symbols</b>	●	Combination possible
	15	Combination possible, typ. switch-on distance 15 mm
		Combination possible, guard locking for process protection
		Combination possible, guard locking for personnel protection
		Combination not permissible

## 3. Description of the safety function

Devices from this series feature the following safety functions:

The following applies in combination with read heads without guard locking (CES read heads) and read heads with guard locking for process protection (CEM read heads):

### Monitoring of the position of a guard (interlocking device according to EN ISO 14119)

- ▶ Safety function:
  - The safety contacts are switched off when the guard is open (see chapter 11. *Technical data on page 20*).
- ▶ Safety characteristics: category, Performance Level, PFH<sub>D</sub> (see chapter 11. *Technical data on page 20*).

The following applies in combination with read heads with guard locking (CET-AX):

### Monitoring of guard locking and the position of the guard (interlocking device with guard locking according to EN ISO 14119)

- ▶ Safety function (see chapter 11. *Technical data on page 20*):
  - The safety contacts are switched off when guard locking is released (monitoring of the locking element).
  - The safety contacts are switched off when the guard is open.
  - Guard locking can be activated only when the actuator is located in the switch head (prevention of inadvertent locking position (faulty closure protection)).
- ▶ Safety characteristics: category, Performance Level, PFH<sub>D</sub> (see chapter 11. *Technical data on page 20*).

### Control of guard locking

- ▶ If the device is used as guard locking for personnel protection, the control of the guard locking must be regarded as a safety function.
- ▶ The device does not feature a safety characteristic for the control of the guard locking, because the guard locking solenoid is completely disconnected from outside the device (no control function within the device). It therefore does not contribute to the failure probability.
- ▶ The safety level for the control of guard locking is determined exclusively by the external control (e.g. PFH<sub>D<sub>ext.</sub></sub> for the standstill monitor).

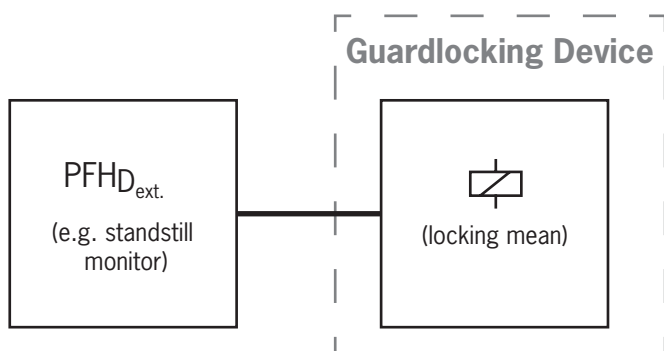

## 4. Exclusion of liability and warranty

In case of failure to comply with the conditions for correct use stated above, or if the safety regulations are not followed, or if any servicing is not performed as required, liability will be excluded and the warranty void.

## 5. General safety precautions



### **WARNING**

Danger to life due to improper installation or due to bypassing (tampering). Safety components fulfill a personnel protection function.

- › Safety components must not be bypassed, turned away, removed or otherwise rendered ineffective. On this topic pay attention in particular to the measures for reducing the possibility of bypassing according to EN ISO 14119:2013, section 7.
- › The switching operation must be triggered only by actuators designated for this purpose.
- › Prevent bypassing by means of replacement actuators (only for multicode evaluation). For this purpose, restrict access to actuators and to keys for releases, for example.
- › Mounting, electrical connection and setup only by authorized personnel possessing the following knowledge:
  - specialist knowledge in handling safety components
  - knowledge about the applicable EMC regulations
  - knowledge about the applicable regulations on operational safety and accident prevention.
- › The number of teach-in and switching operations is saved in the internal memory of the evaluation unit. If necessary, this memory can be read by the manufacturer.



### **Important!**

Prior to use, read the operating instructions and keep these in a safe place. Ensure the operating instructions are always available during mounting, setup and servicing. For this reason you should archive a printed copy of the operating instructions. You can download the operating instructions from [www.euchner.com](http://www.euchner.com).



## 6. Function

The safety system consists of three components:

- Coded actuator
- Read head
- Evaluation unit

The number of read heads that can be connected depends on the evaluation unit:

- CES-AZ-UES-01B: ➔ 1 read head
- CES-AZ-UES-02B: ➔ 2 read heads
- CES-AZ-UES-04B: ➔ 4 read heads

The evaluation unit can be configured so that a start button (monitoring of the falling edge) and a feedback loop can be connected to monitor external relays and contactors. The individual configuration is defined by a setup procedure (see chapter 9. *Setup on page 16*).

Each delivered actuator possesses a unique electronic coding and so is a unique element in the system used. The code in an actuator cannot be reprogrammed.

Unlike systems with unique code detection, on multicode devices a specific code is not requested but instead it is only checked whether the actuator is of a type that can be detected by the system (multicode detection). There is no exact comparison of the actuator code with the taught-in code in the safety switch (unique code detection). The system possesses a low coding level.

The read heads are fastened to the fixed part of the guard and are each connected to the evaluation unit via a two-core shielded cable (terminals H.1, H.2 and SH.).

The actuator fastened to the movable part of the guard is moved towards the read head by closing the door. When the switch-on distance is reached, power is supplied to the actuator by the read head by induction and data can be transferred.

If a permissible code is detected, the door monitoring output O1 or O1...O2 or O1...O4 (semiconductor output) on the related read head is set to HIGH. If all data for all read heads activated match, the safety outputs (relay output) are then enabled. The OUT LED illuminates.

Optionally, a feedback loop can be connected to the evaluation unit. The evaluation unit can then only be started with the feedback loop closed. A welded contactor contact in the enable path will thus be detected the next time the machine is started.

Due to the combination of dynamic polling of the actuators and the redundant, diverse design of the safety electronics with redundantly controlled safety outputs, the evaluation unit will enter the safe state with every detectable fault.

When a guard is opened or when guard locking is released, the safety outputs switch off the safety circuit and the OUT LED goes out. The state of the safety outputs is monitored internally by positively driven NC contacts (relay output).

Independent of the switching state of the safety circuit, the position of all safety doors can be polled via the outputs O1 or O1...O2 or O1...O4.

If an internal fault occurs in the evaluation unit, the safety circuit is switched off, the diagnostic output (DIA) is set to HIGH and the DIA LED illuminates red.

## 6.1. Block diagrams of CES-AZ-UES-...

### CES-AZ-UES-01B

UB, OV	Power supply
J, OV	Jumper for teach-in operation
H11/H12	Read head 1 connection
SH1	Read head 1 shield
TST	Test input (see 9.3.1. Self-test with test input TST on page 18)
O1	Semiconductor monitoring output
DIA	Diagnostic output
13, 14	Connection for relay contact A, safety relay enable
23, 24	Connection for relay contact B, safety relay enable
Y1, Y2	Feedback loop
S	Start button connection (monitoring of the falling edge)

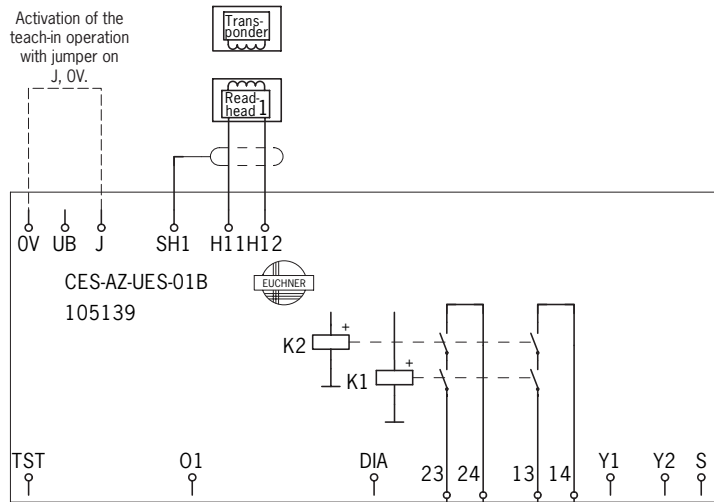

### CES-AZ-UES-02B

UB, OV	Power supply
J1, J2	Jumper for teach-in operation
H11/H12, H21/H22	Connection for read heads 1 and 2
SH1, SH2	Shield for read heads 1 and 2
TST	Test input (see 9.3.1. Self-test with test input TST on page 18)
O1, O2	Semiconductor monitoring outputs
DIA	Diagnostic output
13, 14	Connection for relay contact A, safety relay enable
23, 24	Connection for relay contact B, safety relay enable
Y1, Y2	Feedback loop
S	Start button connection (monitoring of the falling edge)

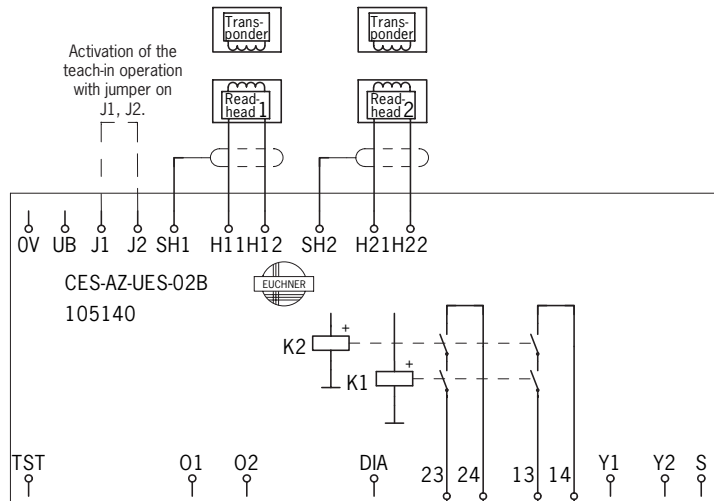

### CES-AZ-UES-04B

UB, OV	Power supply
J1, J2	Jumper for teach-in operation
H11/H12...H41/H42	Connection for read heads 1...4
SH1...SH4	Shield for read heads 1...4
TST	Test input (see 9.3.1. Self-test with test input TST on page 18)
O1...O4	Semiconductor monitoring outputs
DIA	Diagnostic output
13, 14	Connection for relay contact A, safety relay enable
23, 24	Connection for relay contact B, safety relay enable
Y1, Y2	Feedback loop
S	Start button connection (monitoring of the falling edge)

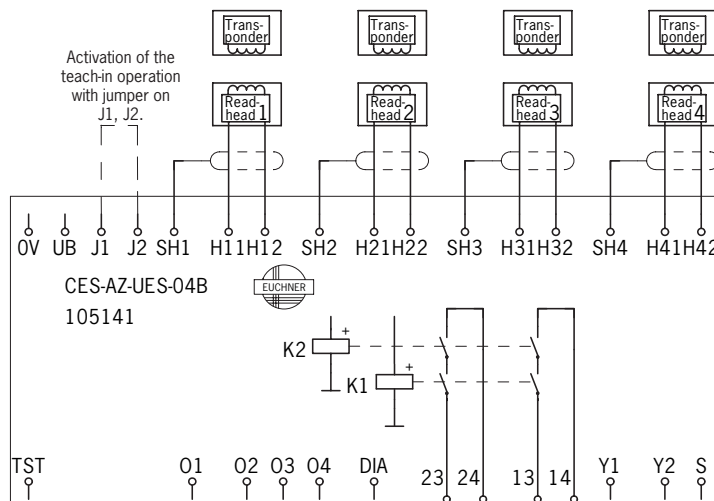

## 7. Mounting



### NOTICE

- Device damage due to improper installation or unsuitable ambient conditions.
- › Read heads and actuators must not be used as a mechanical end stop.
  - › Observe EN ISO 14119:2013, sections 5.2 and 5.3, for information about fastening the safety switch and the actuator.
  - › Observe EN ISO 14119:2013, section 7, for information about reducing the possibilities for bypassing an interlocking device.
  - › The evaluation unit must be mounted in a control cabinet with a minimum degree of protection of IP 54. A snap-in element on the rear of the device is used for fastening to a mounting rail.
  - › If several evaluation units are mounted side by side in a control cabinet without air circulation (e.g. fan), a minimum distance of 10 mm must be maintained between the evaluation units. This distance enables the heat from the evaluation unit to dissipate.



### Important!

- › From the assured release distance  $S_{ar}$ , the safety outputs are safely shut down.
- › When mounting several read heads, observe the stipulated minimum distance to avoid mutual interference.
  - For CES-A-LNA/-LCA  $S_{min} = 50 \text{ mm}$
  - For CES-A-LMN  $S_{min} = 20 \text{ mm}$
  - For CES-A-LQA  $S_{min} = 80 \text{ mm}$
  - For CES-A-LNN  $S_{min} = 160 \text{ mm}$

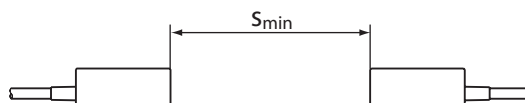

- › If the actuator is installed flush, the switching distance changes as a function of the installation depth and the guard material.

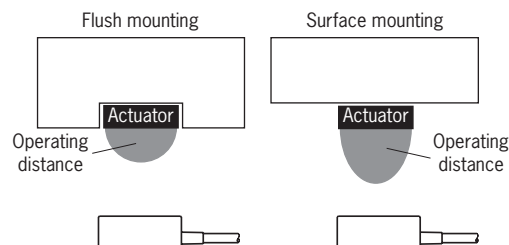

Note the following points:

- › Actuator and read head must be fitted so that
  - the front faces are at the minimum operating distance  $0.8 \times S_{a0}$  or closer when the guard is closed (see section Actuating ranges). To avoid entering the area of possible side lobes, a minimum distance is to be maintained in case of a side approach direction. See section Typical actuating range for the related actuator.
  - a hazard is excluded until the assured release distance ( $S_{ar}$ ) is reached when the guard is open.
  - the actuator is positively mounted on the guard, e.g. by using the safety screws included.
  - they cannot be removed or tampered with using simple means.
- › Pay attention to the maximum tightening torque for the read head or safety switch and actuator fastenings of 1 Nm. For read heads/actuators made of PE-HD, the maximum tightening torque is only 0.5 Nm.

## 8. Electrical connection



### WARNING

- If there is a mistake, loss of the safety function due to incorrect connection.
- › Monitoring outputs must not be used as safety outputs.
  - › Lay the connecting cables with protection to prevent the risk of short circuits.



### NOTICE

- Risk of damage to equipment or malfunctions as a result of incorrect connection.
- › All the electrical connections must either be isolated from the mains supply by a safety transformer according to IEC 61558-2-6 with limited output voltage in the event of a fault, or by other equivalent isolation measures.
  - › All electrical outputs must have an adequate protective circuit for inductive loads. The outputs must be protected with a free-wheeling diode for this purpose. The switch-on current may have to be limited for capacitive loads.
  - › The tightening torque for the screws on the connection terminals must be 0.6 ... 0.8 Nm.
  - › The connection cable for the read heads must only be extended using EUCHNER plug connectors, and adequate consideration must be given to EMC. Intermediate terminals must not be used.
  - › The shield on the connection cable for the read head must be connected to the appropriate terminal SH1 ... 4 on the evaluation unit. The portion of cable from which insulation is stripped should be kept as short as possible (max. 3 cm).

### 8.1. Notes about



### Important!

- › For use and operation as per the  requirements<sup>1)</sup>, a power supply with the feature “for use in Class 2 circuits” must be used.  
Alternative solutions must comply with the following requirements:
  - Electrically isolated power supply unit in combination with fuse as per UL248. This fuse should be designed for max. 3.3 A and should be integrated into the 30 V DC voltage section.

1) Note on the scope of the UL approval: The devices have been tested as per the requirements of UL508 and CSA/C22.2 no. 14 (protection against electric shock and fire).

### 8.2. Safety in case of faults

- › The operating voltage  $U_B$  is reverse polarity protected.
- › The connections for the read heads are not short circuit-proof.
- › A short circuit between 13/14 and 23/24 can be detected only by means of external pulsing.
- › A short circuit in the cable can be excluded by laying the cable with protection.

### 8.3. Fusing of the power supply and the safety contacts

- › Provide external contact fuses (6 A gG fuse or 6 A circuit breaker, characteristic B or C) for relay outputs.
- › The power supply must be protected with a max. 8 A fuse ahead of terminal  $U_B$ .

## 8.4. Connection example for CES-AZ-UES-01B

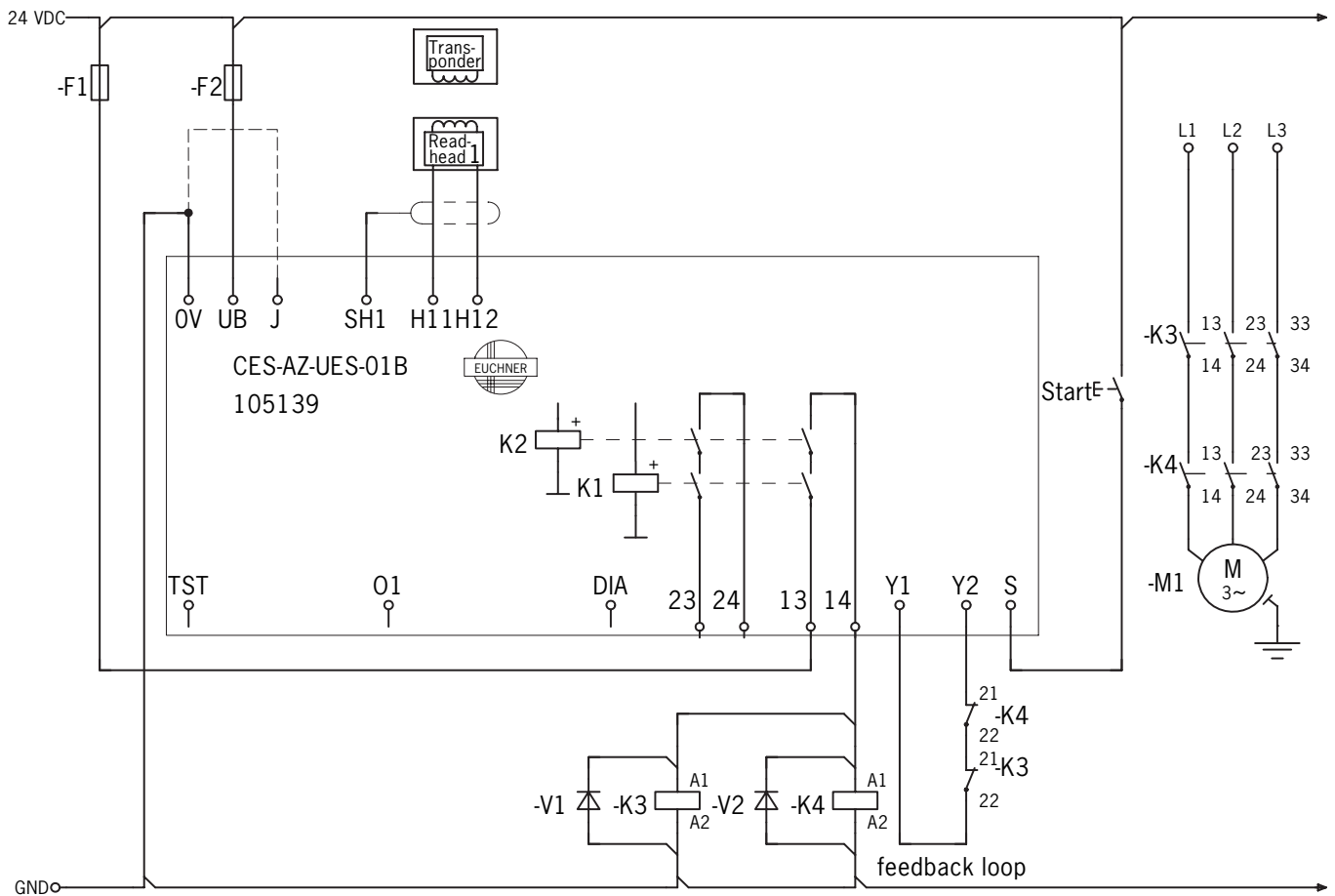

### Important!

To achieve category 4 according to EN ISO 13849-1, it is necessary to monitor the downstream contactors (here: contacts on -K3 and -K4 in the feedback loop).

This example shows only an excerpt that is relevant for the connection of the CES system. The example illustrated here does not show complete system planning. The user is responsible for safe integration into the overall system.

If only one enable path is to be used for control (e.g. of downstream contactors), failures involving a short circuit between the contacts on the enable path and, for example, the power supply must be excluded.

With reference to EN ISO 13849-2 Table D.5, this exclusion can be provided if

- the cables are inside an electrical installation space and
- the enclosure meets the related requirements (see EN 60204-1 or IEC 60204-1).

### 8.5. Connection example for CES-AZ-UES-02B

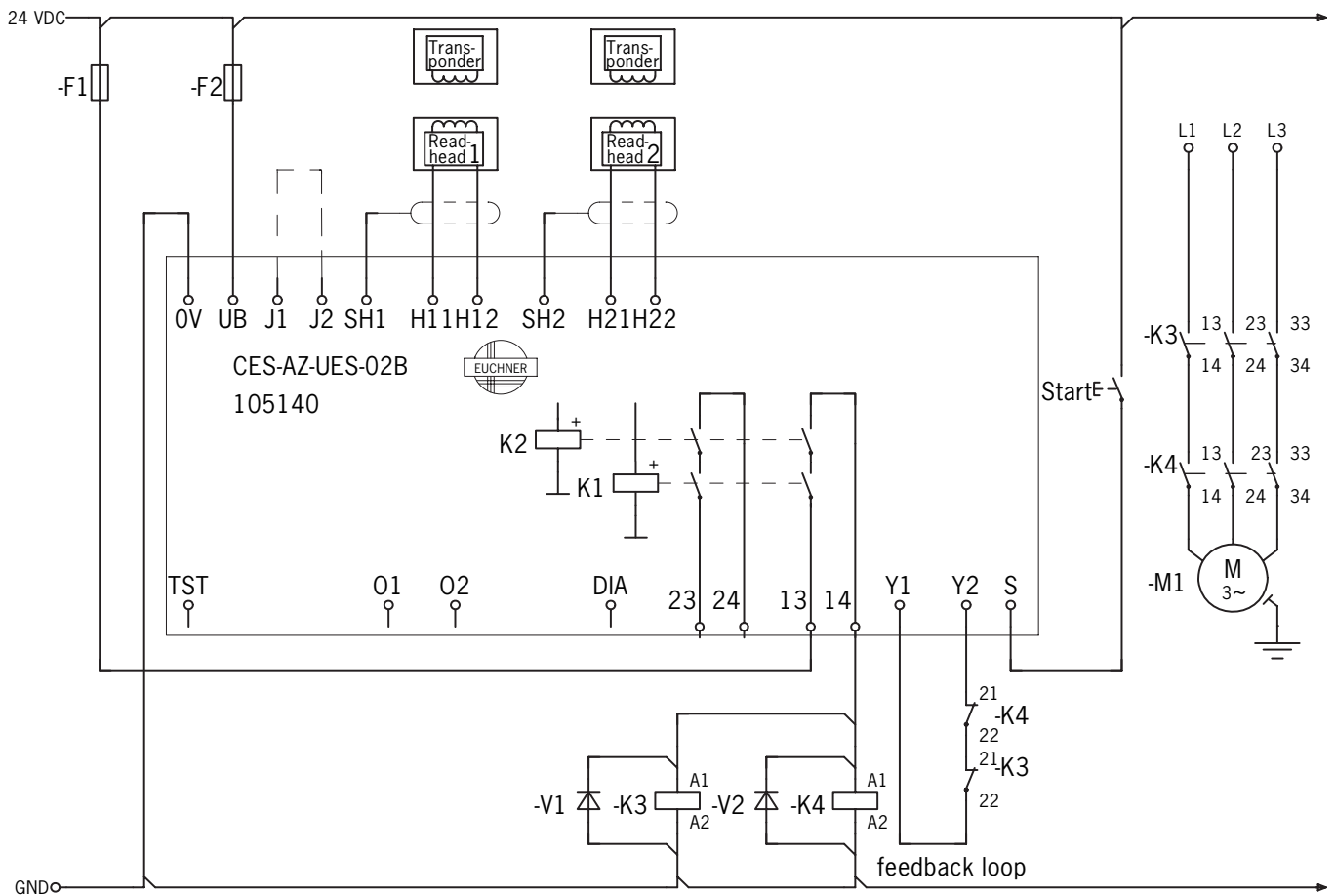

**Important!**

To achieve category 4 according to EN ISO 13849-1, it is necessary to monitor the downstream contactors (here: contacts on -K3 and -K4 in the feedback loop). This example shows only an excerpt that is relevant for the connection of the CES system. The example illustrated here does not show complete system planning. The user is responsible for safe integration into the overall system.

If only one enable path is to be used for control (e.g. of downstream contactors), failures involving a short circuit between the contacts on the enable path and, for example, the power supply must be excluded.

With reference to EN ISO 13849-2 Table D.5, this exclusion can be provided if

- the cables are inside an electrical installation space and
- the enclosure meets the related requirements (see EN 60204-1 or IEC 60204-1).

## 8.6. Connection example for CES-AZ-UES-04B

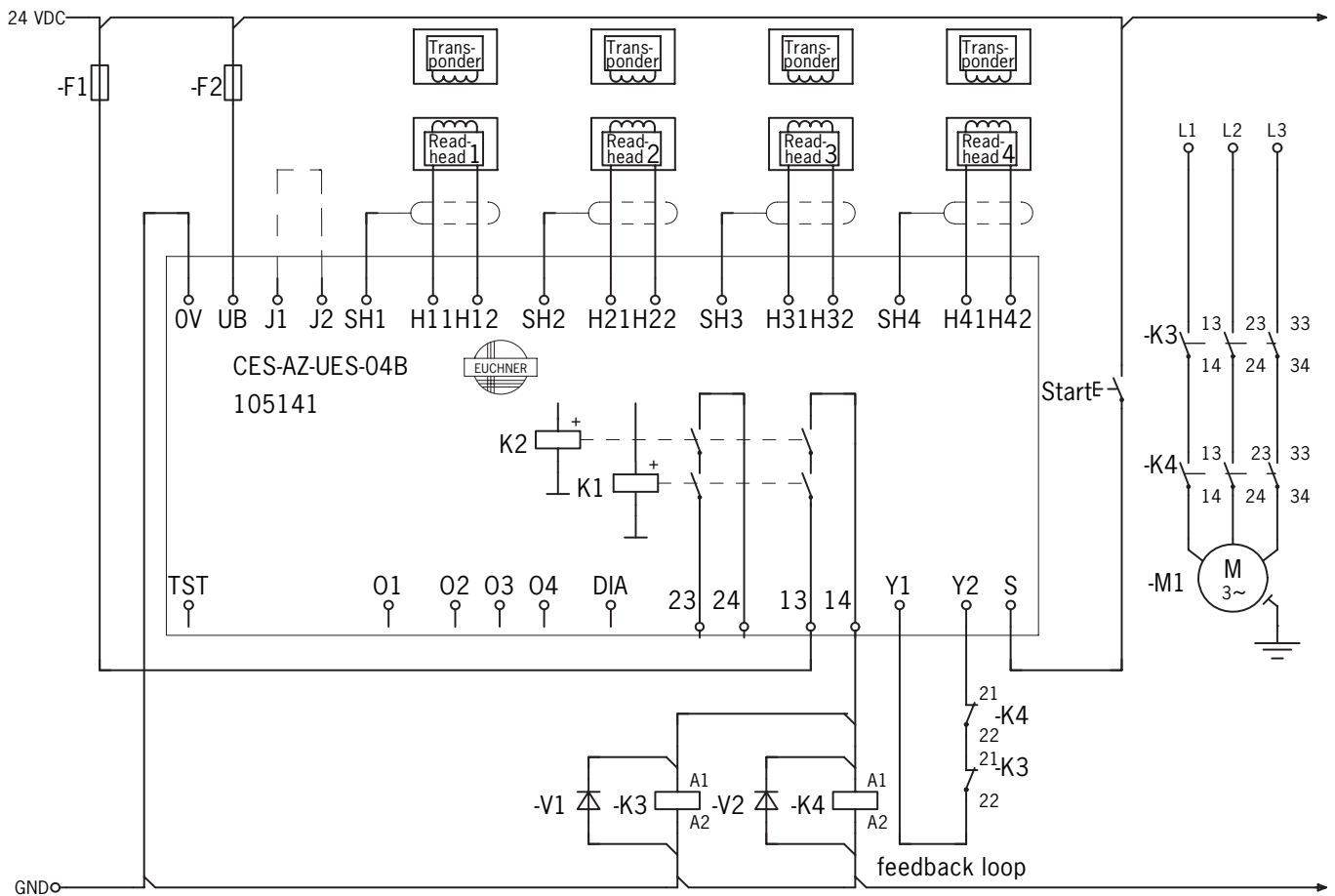

### Important!

To achieve category 4 according to EN ISO 13849-1, it is necessary to monitor the downstream contactors (here: contacts on -K3 and -K4 in the feedback loop).

This example shows only an excerpt that is relevant for the connection of the CES system. The example illustrated here does not show complete system planning. The user is responsible for safe integration into the overall system.

If only one enable path is to be used for control (e.g. of downstream contactors), failures involving a short circuit between the contacts on the enable path and, for example, the power supply must be excluded.

With reference to EN ISO 13849-2 Table D.5, this exclusion can be provided if

- the cables are inside an electrical installation space and
- the enclosure meets the related requirements (see EN 60204-1 or IEC 60204-1).

## 9. Setup

### 9.1. LED indicators

Designation	Color	Meaning
<b>STATE</b>	green	Status indication (multifunction display using flashing modes)
<b>OUT</b>	yellow	Safety circuit closed
<b>DIA</b>	red	<ul style="list-style-type: none"> <li>▸ Operating fault or</li> <li>▸ External fault (fault in the feedback loop) or</li> <li>▸ Invalid parameter setting operation or</li> <li>▸ Internal device fault or</li> <li>▸ TST input activated (function test active)</li> </ul>

### 9.2. Parameter setting

Before the system forms a functional unit, the parameters are set in the evaluation unit by the user (number of connected read heads, with or without automatic start, with or without feedback loop). During this process the read heads are activated.

These configuration parameters are saved in the device.

During the parameter setting operation the safety outputs are open. The system is in the safe state.



#### Important!

- The parameter setting operation can differ for read heads that are not described in this document. Observe the information in the operating instructions for the read head used.
- During the parameter setting the following conditions must be met:
  - There must be no state change, e.g. due to the opening or closing of a safety door or a change in the signal on the terminals for the start button and the feedback loop.
  - The power supply must not be switched off.
- If these conditions are not met, the evaluation unit switches to the safe fault state (diagnostics LED illuminates) and signals this operating fault with the STATE LED by 3 short flashes that are repeated every second. The parameter setting operation must be repeated.
- The number of parameter setting operations is unlimited. The evaluation unit can be re-configured as often as required.
- Do not change DIP switches during operation.

To trigger a parameter setting operation, the user must perform the following actions in the stipulated order:

1. Prepare for parameter setting
  - Switch off power supply  $U_B$
  - Fit a jumper between terminals J1 and J2 (for CES-AZ-UES-01B between J and OV)
2. Set required configuration on DIP switches

Switch designation	Switch position left (OFF)	Switch position right (ON)
1	No read head connected to terminals H11, H12, SH1	Read head connected to terminals H11, H12, SH1
2	No read head connected to terminals H21, H22, SH2	Read head connected to terminals H21, H22, SH2
3	No read head connected to terminals H31, H32, SH3	Read head connected to terminals H31, H32, SH3
4	No read head connected to terminals H41, H42, SH4	Read head connected to terminals H41, H42, SH4
5	Automatic start (no start button connected)	Manual start (start button connected)
6	No feedback loop connected	Feedback loop connected

3. Set required configuration on machine
  - Close all doors to be monitored (the actuators must be in the actuating range of the related read head)
  - For operating mode **Manual start**: keep start button closed
  - For operating mode **with feedback loop**: keep feedback loop closed
4. Start parameter setting operation
  - Switch on operating voltage
  - Wait for self-test (STATE LED flashes for approx. 10 seconds at 15 Hz)



- Parameter setting operation starts (STATE LED flashes at approx. 1 Hz)
  - Wait for acknowledgment of the parameter setting operation (STATE LED goes out after approx. 10 seconds)
5. End parameter setting operation
- Remove jumper between J1 and J2 (for CES-AZ-UES-01B between J and 0V)
  - For operating mode **Manual start**: start button must be connected
  - For operating mode **with feedback loop**: feedback loop must be connected
  - Press reset button or interrupt operating voltage for at least 10 seconds
  - Wait for self-test (STATE LED flashes for approx. 10 seconds at 15 Hz)
6. Check all guards for effectiveness

### 9.2.1. Changing the configuration

The evaluation unit can be re-configured as often as required. For this purpose you must proceed as per the first parameter setting operation according to the section 9.2. *Parameter setting on page 16*.

Faulty actuators can be replaced. The number of parameter setting operations is unlimited.

### 9.3. Functional check

After installation and any fault, the safety function must be fully checked. Proceed as follows:



**WARNING**

Danger of fatal injury as a result of faults in installation and functional check.

- › Before carrying out the functional check, make sure that there are no persons in the danger zone.
- › Observe the valid accident prevention regulations.

1. Switch on operating voltage.
  - The safety switch carries out a self-test.  
The green STATE LED flashes for approx. 10 seconds at 15 Hz.  
The STATE LED then illuminates continuously.  
The OUT and DIA LEDs do not illuminate.
2. Close all guards.
  - The machine must not start automatically.
  - The green STATE LED and the yellow OUT LED light up continuously.
3. Enable operation in the control system.
4. Open the guard.
  - The machine must switch off and it must not be possible to start it as long as the guard is open.
  - The green STATE LED illuminates continuously; the OUT and DIA LEDs do not illuminate.

Repeat steps 2 ... 4 separately for each guard.

#### 9.3.1. Self-test with test input TST

On electromechanical safety switches or magnetic switches, the function test can be performed by cyclically opening the guard.

From category 2 according to EN ISO 13849-1, EN 60204-1 : 1997 (section 9.4.2.4) requires a function test performed on the entire safety system on start-up or after defined intervals.

Testing of the internal function of the unit is not necessary because the device monitors itself in real time. Welding of an output contact (relay output) is detected by the device at the latest the next time the guard is opened. A short circuit in the output cable is not detected by the device.

In addition, the entire safety circuit can be tested without opening the guard. For this purpose, opening of the guard can be simulated by applying 24 V DC to the test input TST.

The safety outputs are switched off, enabling testing of the complete safety circuit. The diagnostic output DIA on the evaluation unit is also set to HIGH as a monitoring function.

When test input TST is reset, the evaluation unit resets the diagnostic output DIA to LOW, the red LED switches off and normal operation is continued.

In Manual start operating mode, the start button must be pressed again to start the system.



**Important!**

After the self-test, the test input TST must be connected to 0 V again or must be disconnected.

## 10. System status table

Operating mode	LED indicator			State
	STATE (green)	OUT (yellow)	DIA (red)	
Setup	4 Hz	○	○	Initial setup after delivery without jumper connected to J1, J2 or J, 0V.
	1 Hz	○	○	Parameter setting operation
	○	○	○	Acknowledgment of completion of parameter setting operation.
Normal operation	15 Hz (10 s)	○	○	Self-test, duration approx. 10 seconds, is performed after the application of the operating voltage U <sub>B</sub>
		○	○	Normal operation, not all monitored doors are closed.
			○	Normal operation, all monitored doors are closed ( <b>after</b> pressing the start button, for Manual start operating mode)
Function test		○		Function test active (TST input = 24 V)
Fault display	○	○		Internal component failure or actuator CES-A-BMB in the impermissible range or excessively high external interference (EMC)
Operating fault		○		Configuration error: <b>Parameter setting operation must be performed again</b> Possible causes: - State change during the parameter setting operation - The DIP switch setting and the configuration did not match during the parameter setting operation - DIP switch setting has been changed without parameter setting operation - The jumper (J1, J2 or J, 0V) was fitted with power supply switched on - Closed feedback loop (Y1,Y2) present, although no feedback loop parameter setting was performed - 24 V signal present at the start button input (S) although parameter setting was performed with "Automatic start" operating mode.
		○		Fault in feedback loop Possible causes: - Malfunction of the monitored contactor - Following removal from the actuating range, actuator is not outside the actuating range long enough; as a result the feedback loop cannot be closed in this short time. Note the release time for the monitored contactor. - Feedback loop was not closed on starting the evaluation unit - Feedback loop was not closed on applying the operating voltage +UB.

Key to symbols	N	0 Volt or not connected
	1	24 Volt
	0	0 Volt
	○	LED not illuminated
		LED illuminated
		LED flashes for 10 seconds at 15 Hz
	+	LED flashes three times and then illuminates continuously
		LED flashes three times, and this is then repeated
	X	Any state



### Important!

If you do not find the displayed device status in the system status table, this indicates an internal device fault. In this case, you should contact the manufacturer.



### NOTICE

The read heads CES-A-LNN and CES-A-LSP have an integrated LED to indicate the door position. The LED illuminates with the guard closed.

## 11. Technical data

### 11.1. Evaluation unit CES-AZ-UES-01B

- › Housing for rail mounting, IP20
- › Relay output
- › 1 read head can be connected

#### Approvals



#### Dimension drawing

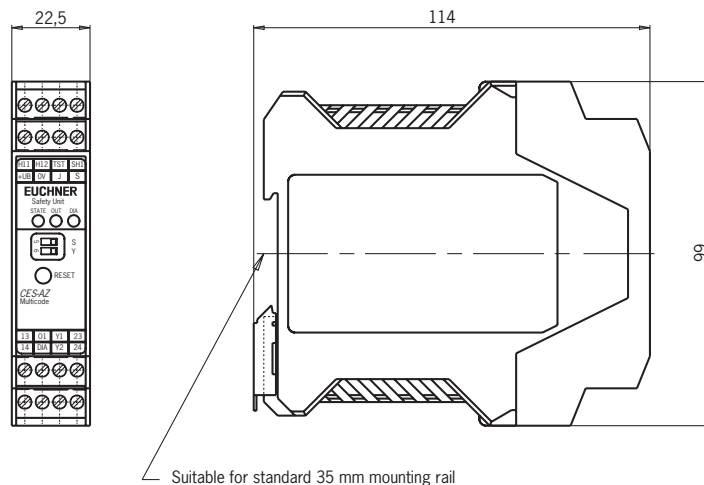

#### Switching characteristics

- › 2 safety outputs with 2 NO contacts each (relay outputs)
- › 1 door monitoring output (semiconductor output, not a safety output)

		Guard	
		closed (actuator detected)	open (actuator not in the actuating range)
Read head	Actuator		
13	14	13—o—o—14	13—o—o—14
23	24	23—o—o—24	23—o—o—24
24 V	01	24 V—o—o—01	24 V—o—o—01



#### Important!

The plug-in screw terminals are not included (see chapter 12. Ordering information and accessories on page 48).

### Technical data for CES-AZ-UES-01B

Parameter	Value			Unit
	min.	typ.	max.	
Housing material	PA6.6 plastic			
Dimensions	114 x 99 x 22.5			mm
Weight	0.2			kg
Ambient temperature at $U_B = DC 24 V$	-20	-	+55	°C
Atmospheric humidity, not condensing	-	-	80	%
Degree of protection	IP20			
Degree of contamination	2			
Mounting	Mounting rail 35 mm according to EN 60715 TH35			
Number of read heads	1 read head per evaluation unit			
Connection cross-section (plug-in connection terminals, coded)	0.25	-	2.5	mm <sup>2</sup>
Operating voltage $U_B$ (regulated, residual ripple < 5%)	21	24	27	V DC
For the approval according to $\bullet\text{UL}\bullet$ the following applies	Operation only with UL class 2 power supply or equivalent measures			
Current consumption $I_B$ (with relay energized) <sup>1)</sup>	-	150	-	mA
External fuse (operating voltage $U_B$ )	0.25	-	8	A
Safety contacts	2 (relays with internally monitored contacts)			
Switching current (relay outputs)				
- at switching voltage AC/DC 21 ... 60 V	1	-	300	mA
- at switching voltage AC/DC 5 ... 30 V	10	-	6000	
- at switching voltage AC5 ... 230 V (160 V ATEX)	10	-	2000	
Switching load according to $\bullet\text{UL}\bullet$	Class 2 max. 30 V AC/Class 2 max. 60 V DC 120 V AC 3 A / 240 V AC 1.5 A			
External fuse (safety circuit) according to EN 60269-1	6 AgG or 6 A circuit breaker (characteristic B or C)			
Utilization category according to EN 60947-5-1	AC-12 60 V 0.3 A / DC-12 60 V 0.3 A AC-12 30 V 6 A / DC-12 30 V 6 A AC-15 230 V 2 A / DC-13 24 V 3 A			
Rated insulation voltage $U_i$	250			V
Rated impulse withstand voltage $U_{imp}$	4			kV
Rated conditional short-circuit current	100			A
Resilience to vibration	Acc. to EN 60947-5-2			
Mechanical operating cycles (relays)	10 x 10 <sup>6</sup>			
Switching delay from state change <sup>2)</sup>	-	-	210	ms
Discrepancy time (of the switching points of both relays)	-	-	25	ms
Current via feedback loop Y1/Y2	5	8	10	mA
Permissible resistance via feedback loop	-	-	600	$\Omega$
Ready delay <sup>3)</sup>	-	10	12	s
Dwell time <sup>4)</sup>	3	-	-	s
Switching frequency max. <sup>5)</sup>	-	-	0.25	Hz
Repeat accuracy R acc. to EN IEC 60947-5-3	$\leq 10$			%
Monitoring outputs (diagnostics DIA, door monitoring output O1, semiconductor output, p-switching, short circuit-protected)				
- Output voltage	0.8 x $U_B$	-	$U_B$	V DC
- Max. load	-	-	20	mA
Start button input S, test input TST				
- Input voltage LOW	0	-	2	V DC
- Input voltage HIGH	15	-	$U_B$	
- Input current HIGH	5	8	10	mA
EMC protection requirements	Acc. to EN 60947-5-3			
<b>Reliability values acc. to EN ISO 13849-1 as a function of the switching current at 24 V DC</b>				
	$\leq 0.1 A$	$\leq 1 A$	$\leq 3 A$	
Category	4			
Performance Level (PL)	e			
PFF <sub>D</sub>	1.9 x 10 <sup>-8</sup>			
Mission time	20			years
Number of switching cycles/year	760 000	153 000	34 600	
Diagnostic coverage DC	99			%
MTTF <sub>D</sub>	136			years

1) Without taking into account the load currents on the monitoring outputs.

2) Corresponds to the risk time according to EN 60947-5-3. This is the maximum OFF time for the safety outputs following removal of the actuator. In case of EMC interference in excess of the requirements in accordance with EN 60947-5-3, the OFF time can increase to max. 250 ms. After a brief actuation < 0.25 s, the switch-on delay can increase to max. 3 s if this is followed immediately by further actuation.

3) After the operating voltage is switched on, the relay outputs are switched off and the door monitoring output is set to LOW potential during the ready delay. For the visual indication of the delay, the green STATE LED flashes at a frequency of approx. 15 Hz.

4) The dwell time is the time that the actuator must be outside the actuating range.

5) In case of monitoring with feedback loop, the actuators must remain outside the actuating range, e.g. with a door open, until the feedback loop is closed.

## 11.2. Evaluation unit CES-AZ-UES-02B

- › Housing for rail mounting, IP20
- › Relay output
- › 2 read heads can be connected

### Approvals



### Dimension drawing

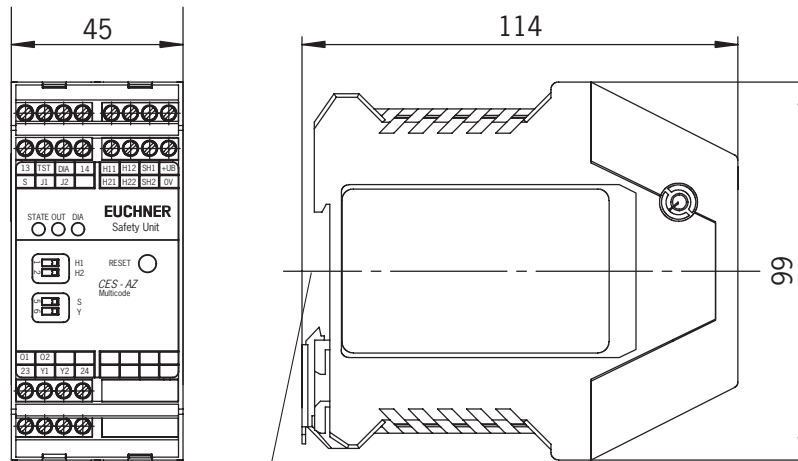

Suitable for 35 mm mounting rail according to EN 60715

### Switching characteristics

- › 2 safety outputs with 2 NO contacts each (relay outputs)
- › 2 door monitoring outputs (semiconductor outputs, not safety outputs)

		Guard	
		closed (all actuators detected)	open (e.g. actuator 1 not in the actuating range)
Read head 1	Actuator 1	Read head 1	
13	14	13	14
23	24	23	24
24V	01	24V	01
24V	02	24V	02



### Important!

The plug-in screw terminals are not included (see chapter 12. *Ordering information and accessories on page 48*).

### Technical data for CES-AZ-UES-02B

Parameter	Value			Unit
	min.	typ.	max.	
Housing material	PA6.6 plastic			
Dimensions	114 x 99 x 45			mm
Weight	0.25			kg
Ambient temperature at $U_B = DC 24 V$	-20	-	+55	°C
Atmospheric humidity, not condensing	-	-	80	%
Degree of protection	IP20			
Degree of contamination	2			
Mounting	Mounting rail 35 mm according to EN 60715 TH35			
Number of read heads	Max. 2 read heads per evaluation unit			
Connection cross-section (plug-in connection terminals, coded)	0.25	-	2.5	mm <sup>2</sup>
Operating voltage $U_B$ (regulated, residual ripple < 5%)	21	24	27	V DC
For the approval according to $\text{UL}$ the following applies	Operation only with UL class 2 power supply or equivalent measures			
Current consumption $I_B$ (with relay energized) <sup>1)</sup>	-	150	-	mA
External fuse (operating voltage $U_B$ )	0.25	-	8	A
Safety contacts	2 (relays with internally monitored contacts)			
Switching current (relay outputs)				
- at switching voltage AC/DC 21 ... 60 V	1	-	300	mA
- at switching voltage AC/DC 5 ... 30 V	10	-	6000	
- at switching voltage AC 5 ... 230 V	10	-	2000	
Switching load according to $\text{UL}$	Class 2 max. 30 V AC/Class 2 max. 60 V DC 120 V AC 3 A / 240 V AC 1.5 A			
External fuse (safety circuit) according to EN 60269-1	6 AgG or 6 A circuit breaker (characteristic B or C)			
Utilization category according to EN 60947-5-1	AC-12 60 V 0.3 A / DC-12 60 V 0.3 A AC-12 30 V 6 A / DC-12 30 V 6 A AC-15 230 V 2 A / DC-13 24 V 3 A			
Rated insulation voltage $U_i$	250			V
Rated impulse withstand voltage $U_{imp}$	4			kV
Rated conditional short-circuit current	100			A
Resilience to vibration	Acc. to EN 60947-5-2			
Mechanical operating cycles (relays)	10 x 10 <sup>6</sup>			
Switching delay from state change <sup>2)</sup>				
- 2 actuators activated	-	-	290	ms
- 1 actuator activated	-	-	210	
Discrepancy time of the operating points of both relays (with 2 activated actuators)	-	-	25	ms
Manual start operating mode				
- Start button actuating duration	250	-	-	ms
- Start button response delay	-	200	300	
Current via feedback loop Y1/Y2	5	8	10	mA
Permissible resistance via feedback loop	-	-	600	$\Omega$
Ready delay <sup>3)</sup>	-	10	12	s
Dwell time <sup>4)</sup>	3	-	-	s
Switching frequency max. <sup>5)</sup>	-	-	0.25	Hz
Repeat accuracy R acc. to EN IEC 60947-5-3	$\leq 10$			%
Monitoring outputs (diagnostics DIA, door monitoring outputs O1...O2, semiconductor output, p-switching, short circuit-protected)				
- Output voltage	0.8 x $U_B$	-	$U_B$	V DC
- Max. load	-	-	20	
Start button input S, test input TST				
- Input voltage LOW	0	-	2	V DC
- Input voltage HIGH	15	-	$U_B$	
- Input current HIGH	5	8	10	
EMC protection requirements	Acc. to EN 60947-5-3			
<b>Reliability values acc. to EN ISO 13849-1 as a function of the switching current at 24 V DC</b>				
	$\leq 0.1 A$	$\leq 1 A$	$\leq 3 A$	
Category	4			
Performance Level (PL)	e			
PFH <sub>D</sub>	1.9 x 10 <sup>-8</sup>			
Mission time	20			years
Number of switching cycles/year	760 000	153 000	34 600	
Diagnostic coverage DC	99			%
MTTF <sub>D</sub>	136			years

1) Without taking into account the load currents on the monitoring outputs.

2) Corresponds to the risk time according to EN 60947-5-3. This is the maximum OFF time for the safety outputs following removal of the actuator. In case of EMC interference in excess of the requirements in accordance with EN 60947-5-3, the OFF time can increase to max. 430 ms. After a brief actuation < 0.4 s, the switch-on delay can increase to max. 3 s if this is followed immediately by further actuation.

3) After the operating voltage is switched on, the relay outputs are switched off and the monitoring outputs are set to LOW potential during the ready delay. For the visual indication of the delay, the green STATE LED flashes at a frequency of approx. 15 Hz.

4) The dwell time is the time that the actuator must be outside the actuating range.

5) In case of monitoring with feedback loop, the actuators must remain outside the actuating range, e.g. with a door open, until the feedback loop is closed.

## 11.3. Evaluation unit CES-AZ-UES-04B

- › Housing for rail mounting, IP20
- › Relay output
- › 4 read heads can be connected

### Approvals



### Dimension drawing

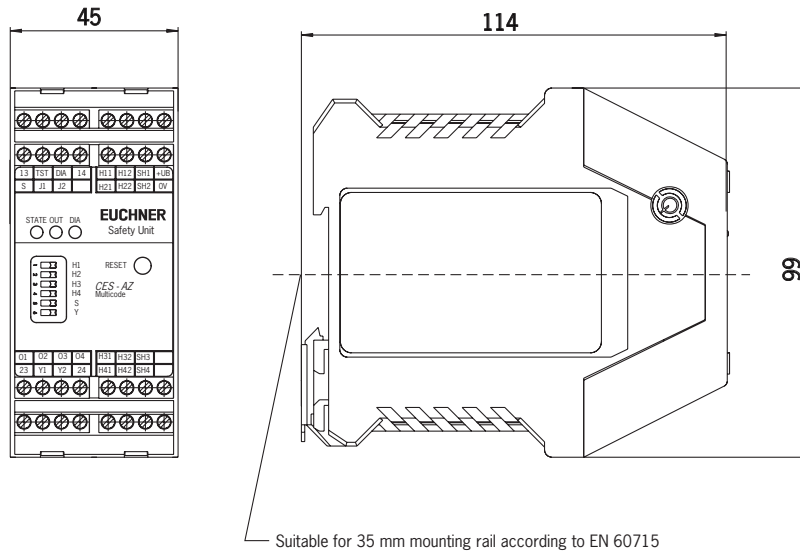

### Switching characteristics

- › 2 safety outputs with 2 NO contacts each (relay outputs)
- › 4 door monitoring outputs (semiconductor outputs, not safety outputs)

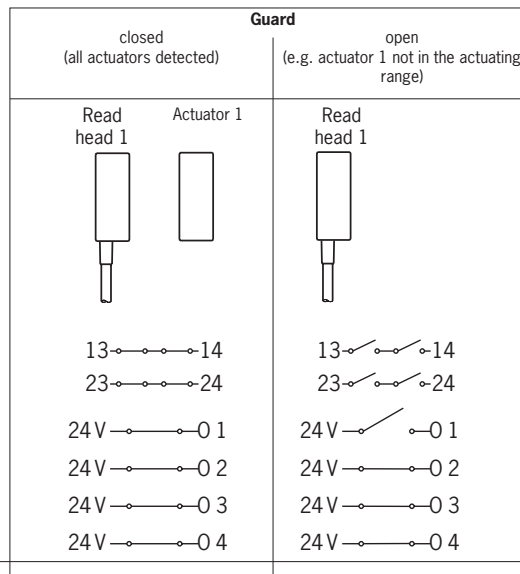

### Important!

The plug-in screw terminals are not included (see chapter 12. Ordering information and accessories on page 48).



### Technical data for CES-AZ-UES-04B

Parameter	Value			Unit
	min.	typ.	max.	
Housing material	PA6.6 plastic			
Dimensions	114 x 99 x 45			mm
Weight	0.25			kg
Ambient temperature at $U_B = DC 24 V$	-20	-	+55	°C
Atmospheric humidity, not condensing	-	-	80	%
Degree of protection	IP20			
Degree of contamination	2			
Mounting	Mounting rail 35 mm according to EN 60715 TH35			
Number of read heads	Max. 4 read heads per evaluation unit			
Connection cross-section (plug-in connection terminals, coded)	0.25	-	2.5	mm <sup>2</sup>
Operating voltage $U_B$ (regulated, residual ripple < 5%)	21	24	27	V DC
For the approval according to «UL» the following applies	Operation only with UL class 2 power supply or equivalent measures			
Current consumption $I_B$ (with relay energized) <sup>1)</sup>	-	150	-	mA
External fuse (operating voltage $U_B$ )	0.25	-	8	A
Safety contacts	2 (relays with internally monitored contacts)			
Switching current (relay outputs)				
- at switching voltage AC/DC 21 ... 60 V	1	-	300	mA
- at switching voltage AC/DC 5 ... 30 V	10	-	6000	
- at switching voltage AC 5 ... 230 V	10	-	2000	
Switching load according to «UL»	Class 2 max. 30 V AC/Class 2 max. 60 V DC 120 V AC 3 A / 240 V AC 1.5 A			
External fuse (safety circuit) according to EN 60269-1	6 AgG or 6 A circuit breaker (characteristic B or C)			
Utilization category according to EN 60947-5-1	AC-12 60 V 0.3 A / DC-12 60 V 0.3 A AC-12 30 V 6 A / DC-12 30 V 6 A AC-15 230 V 2 A / DC-13 24 V 3 A			
Rated insulation voltage $U_i$	250			V
Rated impulse withstand voltage $U_{imp}$	4			kV
Rated conditional short-circuit current	100			A
Resilience to vibration	Acc. to EN 60947-5-2			
Mechanical operating cycles (relays)	10 x 10 <sup>6</sup>			
Switching delay from state change <sup>2)</sup>				
- 4 activated actuators	-	-	450	ms
- 3 activated actuators	-	-	370	
- 2 actuators activated	-	-	290	
- 1 actuator activated	-	-	210	
Discrepancy time of the operating points of both relays (with 4 activated actuators)	-	-	25	ms
Manual start operating mode				
- Start button actuating duration	250	-	-	ms
- Start button response delay	-	200	300	
Current via feedback loop Y1/Y2	5	8	10	mA
Permissible resistance via feedback loop	-	-	600	Ω
Ready delay <sup>3)</sup>	-	10	12	s
Dwell time <sup>4)</sup>	3	-	-	s
Switching frequency max. <sup>5)</sup>	-	-	0.25	Hz
Repeat accuracy R acc. to EN IEC 60947-5-3	≤ 10			%
Monitoring outputs (diagnostics DIA, door monitoring outputs O1...O4, semiconductor output, p-switching, short circuit-protected)				
- Output voltage	0.8 x $U_B$	-	$U_B$	V DC
- Max. load	-	-	20	mA
Start button input S, test input TST				
- Input voltage LOW	0	-	2	V DC
- Input voltage HIGH	15	-	$U_B$	
- Input current HIGH	5	8	10	mA
EMC protection requirements	Acc. to EN 60947-5-3			
<b>Reliability values acc. to EN ISO 13849-1 as a function of the switching current at 24 V DC</b>				
	≤ 0.1 A	≤ 1 A	≤ 3 A	
Category	4			
Performance Level (PL)	e			
PFH <sub>D</sub>	1.9 x 10 <sup>-8</sup>			
Mission time	20			years
Number of switching cycles/year	760 000	153 000	34 600	
Diagnostic coverage DC	99			%
MTTF <sub>D</sub>	136			years

1) Without taking into account the load currents on the monitoring outputs.

2) Corresponds to the risk time according to EN 60947-5-3. This is the maximum OFF time for the safety outputs following removal of the actuator. In case of EMC interference in excess of the requirements in accordance with EN 60947-5-3, the OFF time can increase to max. 750 ms. After a brief actuation < 0.8 s, the switch-on delay can increase to max. 3 s if this is followed immediately by further actuation.

3) After the operating voltage is switched on, the relay outputs are switched off and the monitoring outputs are set to LOW potential during the ready delay. For the visual indication of the delay, the green STATE LED flashes at a frequency of approx. 15 Hz.

4) The dwell time is the time that the actuator must be outside the actuating range.

5) In case of monitoring with feedback loop, the actuators must remain outside the actuating range, e.g. with a door open, until the feedback loop is closed.

## 11.4. Read head CES-A-LNN-...

- › Cube-shaped design 42 x 25 mm
- › Attachment compatible with series CES-A-LNA/LCA
- › LED for the indication of the door position

Approvals



### Dimension drawing

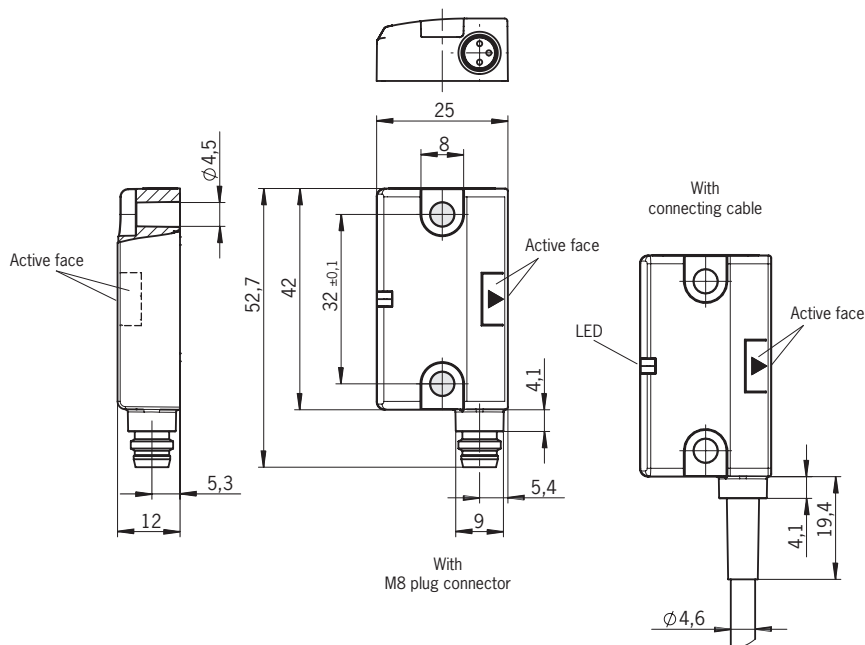

### Typical actuating range

With evaluation unit CES-AZ-UES-... and actuator CES-A-BBN

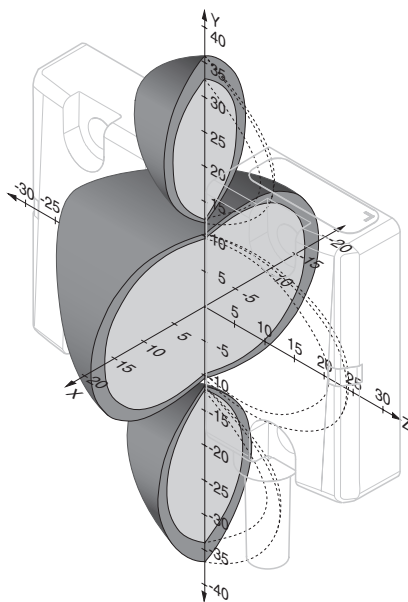

### NOTICE

For a side approach direction for the actuator and read head, a minimum distance of  $s = 6$  mm must be maintained so that the actuating range of the side lobes is not entered.

## Terminal assignment

Read head with connection cable

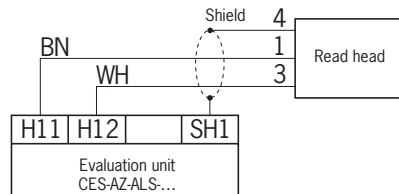

## Technical data

Parameter	Value			Unit	
	min.	typ.	max.		
Housing material	Reinforced thermoplastic (PBT), fully encapsulated				
Dimensions	42 x 25 x 12			mm	
Weight (without connection cable)	0.025			kg	
Ambient temperature	-25	-	+70	°C	
Degree of protection	IP67				
Installation orientation	Any				
Method of operation	Inductive				
Power supply	Via evaluation unit				
Connection	M8 plug connector, 3-pin or connection cable				
LED indicator	White, valid actuator detected				
<b>In combination with actuator CES-A-BBN-106600</b>					
Assured release distance $S_{ar}$	in x/z direction	-	-	50	mm
	in y direction	-	-	100	
Actuating range for center offset $m = 0$ <sup>1)</sup>					mm
- Switch-on distance	-	15	-		
- Assured switch-on distance $S_{ao}$	10	-	-		
- Switching hysteresis	1	4	-		
<b>In combination with actuator CES-A-BDN-06-104730</b>					
Assured release distance $S_{ar}$	in x/z direction	-	-	50	mm
	in y direction	-	-	80	
Actuating range for center offset $m = 0$ <sup>1)</sup>					mm
- Switch-on distance	-	19	-		
- Assured switch-on distance $S_{ao}$	14	-	-		
- Switching hysteresis	-	4	-		
Cable length	See chapter 12. <i>Ordering information and accessories on page 48</i>			25	m

1) These values apply to surface installation of the read head and the actuator.

### 11.5. Read head CES-A-LSP-...

- › Optimized for aluminum profile mounting
- › LED for the indication of the door position

Approvals



#### Dimension drawing

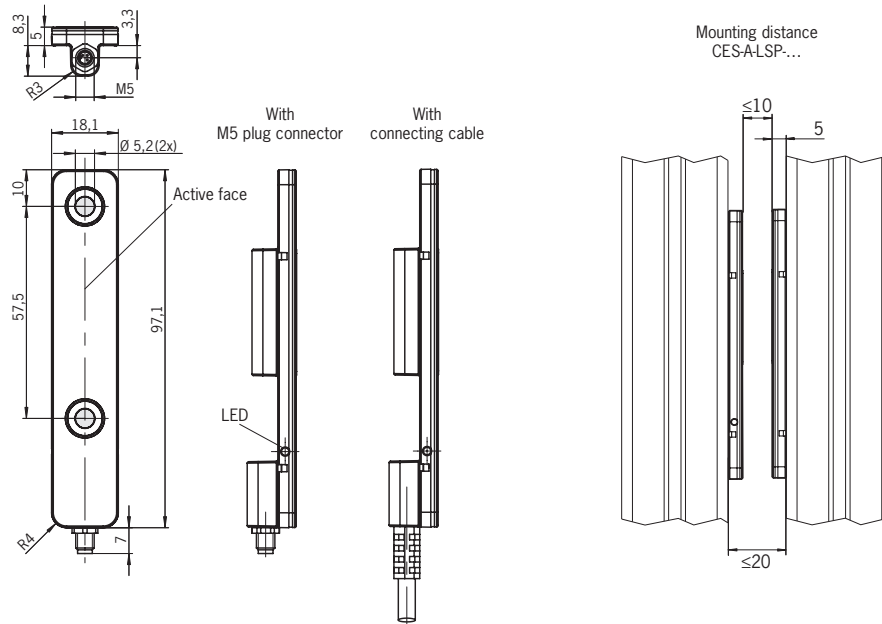

#### Typical actuating range

With evaluation unit CES-AZ-UES-... and actuator CES-A-BSP

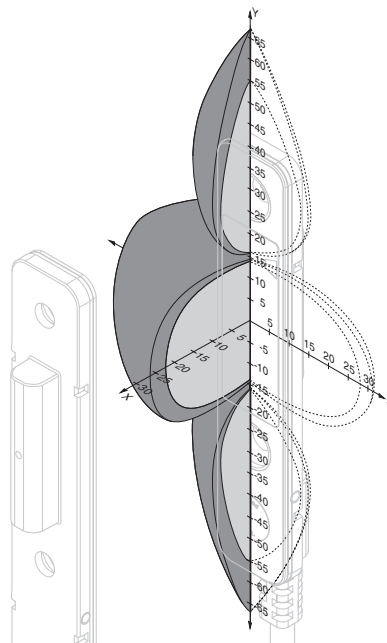

#### NOTICE

For a side approach direction for the actuator and read head, a minimum distance of  $s = 6$  mm must be maintained so that the actuating range of the side lobes is not entered.

## Terminal assignment

Read head with connection cable

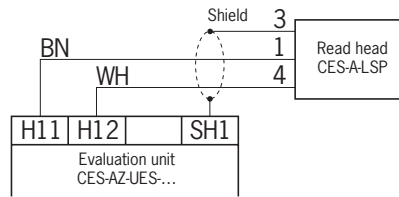

## Technical data

Parameter	Value			Unit
	min.	typ.	max.	
Housing material	PA6 GF30			
Weight (without connection cable)	0.02			kg
Ambient temperature	-25	-	+70	°C
Degree of protection	IP67			
Installation orientation	Any			
Method of operation	Inductive			
Power supply	Via evaluation unit			
Connection	M5 plug connector, 3-pin			
LED indicator	White, valid actuator detected			
<b>In combination with actuator CES-A-BSP-104970</b>				
Assured release distance $S_{ar}$	-	-	45	mm
Actuating range for center offset $m = 0$ <sup>1)</sup> with vertical approach direction (x direction)				
- Switch-on distance	-	20	-	
- Assured switch-on distance $S_{ao}$	10	-	-	
- Switching hysteresis	1	4	-	
Cable length	See chapter 12. Ordering information and accessories on page 48			m

1) These values apply to installation of the read head and the actuator in an aluminum profile 45 x 45 mm.

## 11.6. Read head CES-A-LNA-...

- Cube-shaped design 42 x 25 mm
- Hard-wired cable

### Approvals



### Dimension drawing

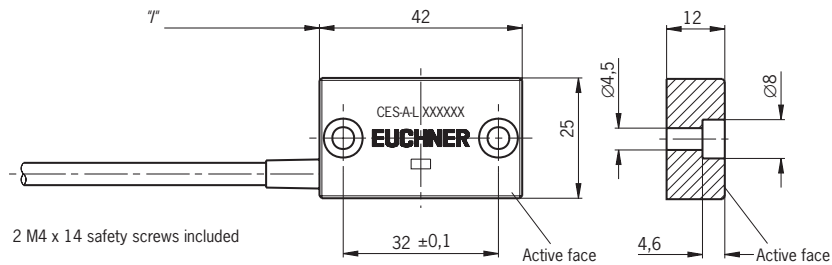

### Typical actuating range

With evaluation unit CES-AZ-UES-... and actuator CES-A-BBA

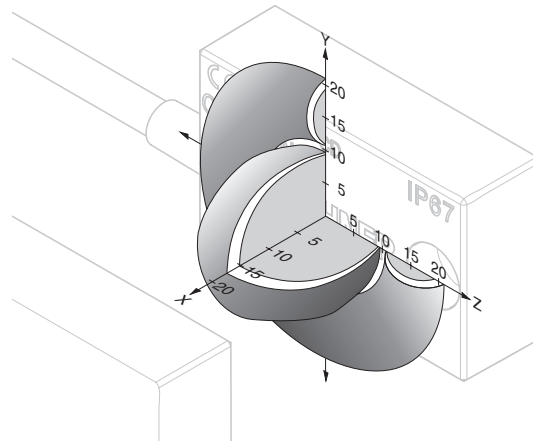

### NOTICE

For a side approach direction for the actuator and read head, a minimum distance of  $s = 3$  mm must be maintained so that the actuating range of the side lobes is not entered.

## Terminal assignment

Read head with connection cable

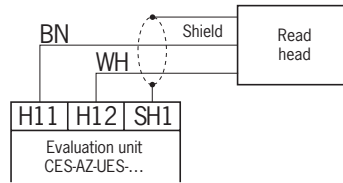

## Technical data

Parameter	Value			Unit
	min.	typ.	max.	
Housing material	Fortron, reinforced thermoplastic, fully encapsulated			
Dimensions	42 x 25 x 12			mm
Weight (incl. 10 m cable)	0.3			kg
Ambient temperature	-25	-	+70	°C
Degree of protection	IP67/IP69K			
Installation orientation	Any			
Method of operation	Inductive			
Power supply	Via evaluation unit			
<b>In combination with actuator CES-A-BBA</b>				
Assured release distance $S_{ar}$	-	-	26	mm
Actuating range for center offset $m = 0$ <sup>1)</sup>				
- Switch-on distance	-	15	-	
- Assured switch-on distance $S_{ao}$	10	-	-	
- Switching hysteresis	0.5	2	-	
Minimum distance $s$ for side approach direction	3	-	-	
<b>In combination with actuator CES-A-BDA-20</b>				
Assured release distance $S_{ar}$	-	-	33	mm
Actuating range for center offset $m = 0$ <sup>2)</sup>				
- Switch-on distance	-	16	-	
- Assured switch-on distance $S_{ao}$	11	-	-	
- Switching hysteresis	0.5	2	-	
Minimum distance $s$ for side approach direction	4	-	-	
<b>In combination with actuator CES-A-BDA-18</b>				
Assured release distance $S_{ar}$	-	-	32	mm
Actuating range for center offset $m = 0$ <sup>1)</sup>				
- Switch-on distance	-	16	-	
- Assured switch-on distance $S_{ao}$	10	-	-	
- Switching hysteresis	0.5	1.4	-	
Minimum distance $s$ for side approach direction	5	-	-	
Connecting cable	Hard-wired encapsulated connection cable, with crimped ferrules PVC, $\varnothing$ 4.6 mm PUR, $\varnothing$ 4.8 mm, suitable for drag chain			
Cable length	-	-	25	m

- 1) These values apply to surface installation of the read head and the actuator.  
2) These values apply to non-metallic surrounding material. Other materials on request.

## 11.7. Read head CES-A-LNA-SC

- Cube-shaped design 42 x 25 mm
- M8 plug connector

### Approvals



### Dimension drawing

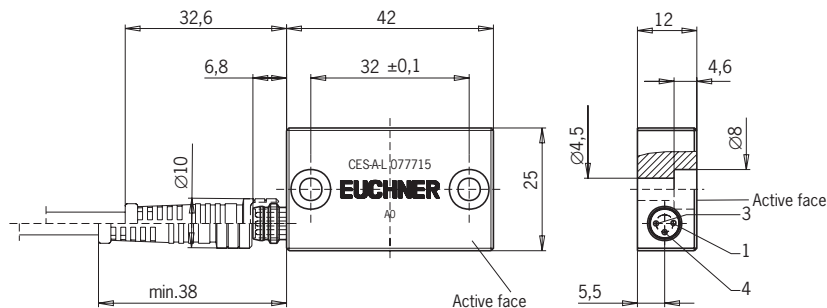

2 M4 x 14 safety screws included

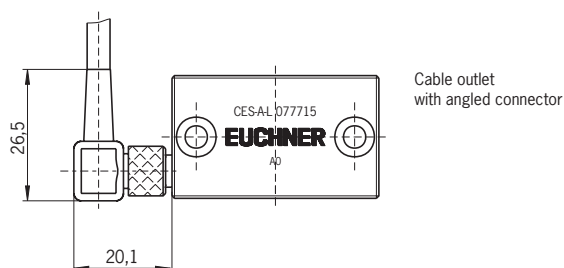

Cable outlet  
with angled connector

### Typical actuating range

With evaluation unit CES-AZ-UES-... and actuator CES-A-BBA

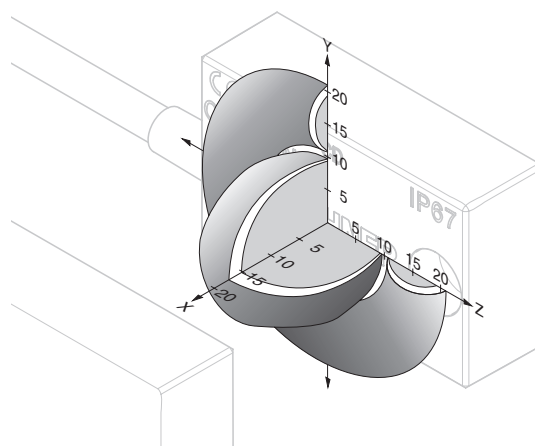

### NOTICE

For a side approach direction for the actuator and read head, a minimum distance of  $s = 3$  mm must be maintained so that the actuating range of the side lobes is not entered.



## Terminal assignment

Read head with plug connector

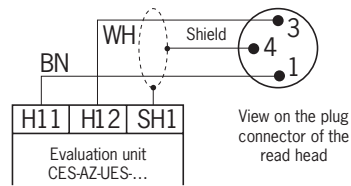

## Technical data

Parameter	Value			Unit
	min.	typ.	max.	
Housing material	Fortron, reinforced thermoplastic, fully encapsulated			
Dimensions	42 x 25 x 12			mm
Weight (incl. 10 m cable)	0.3			kg
Ambient temperature	-25	-	+70	°C
Degree of protection	IP67/IP69K			
Installation orientation	Any			
Method of operation	Inductive			
Power supply	Via evaluation unit			
<b>In combination with actuator CES-A-BBA</b>				
Assured release distance $S_{ar}$	-	-	26	mm
Actuating range for center offset $m = 0$ <sup>1)</sup>				
- Switch-on distance	-	15	-	
- Assured switch-on distance $S_{ao}$	10	-	-	
- Switching hysteresis	0.5	2	-	
Minimum distance $s$ for side approach direction	3	-	-	
<b>In combination with actuator CES-A-BDA-20</b>				
Assured release distance $S_{ar}$	-	-	33	mm
Actuating range for center offset $m = 0$ <sup>2)</sup>				
- Switch-on distance	-	16	-	
- Assured switch-on distance $S_{ao}$	11	-	-	
- Switching hysteresis	0.5	2	-	
Minimum distance $s$ for side approach direction	4	-	-	
<b>In combination with actuator CES-A-BDA-18</b>				
Assured release distance $S_{ar}$	-	-	32	mm
Actuating range for center offset $m = 0$ <sup>1)</sup>				
- Switch-on distance	-	16	-	
- Assured switch-on distance $S_{ao}$	10	-	-	
- Switching hysteresis	0.5	1.4	-	
Minimum distance $s$ for side approach direction	5	-	-	
Connection	M8 plug connector, 3-pin			
Connecting cable	-	-	25	m

1) These values apply to surface installation of the read head and the actuator.

2) These values apply to non-metallic surrounding material. Other materials on request.

## 11.8. Read head CES-A-LCA-...

- Cube-shaped design 42 x 25 mm
- PE-HD plastic housing material, suitable for use in aggressive media (e.g. acids, alkalis)

### Approvals



### Dimension drawing

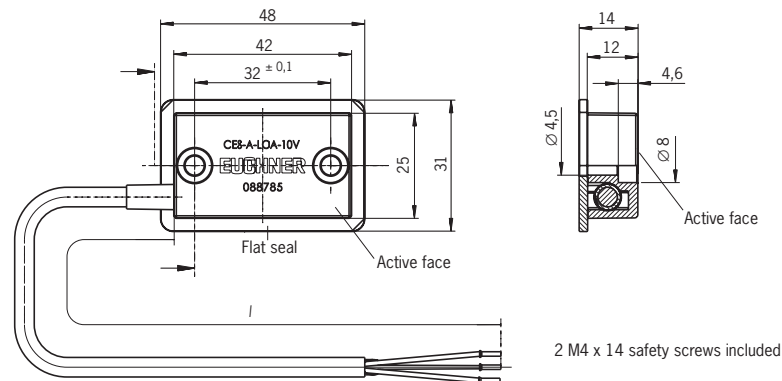

### NOTICE

The flat seal provided must be used during assembly.

### Typical actuating range

With evaluation unit CES-AZ-UES-... and actuator CES-A-BCA

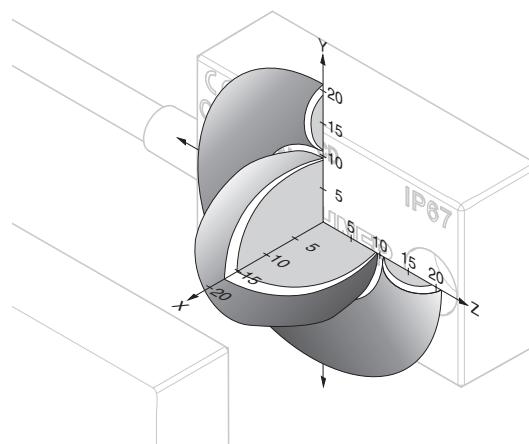

### NOTICE

For a side approach direction for the actuator and read head, a minimum distance of  $s = 3$  mm must be maintained so that the actuating range of the side lobes is not entered.

## Terminal assignment

Read head with connection cable

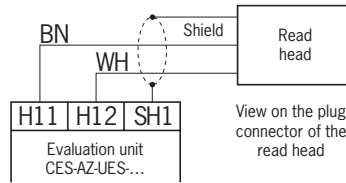

## Technical data

Parameter	Value			Unit
	min.	typ.	max.	
Housing material	PE-HD plastic without reinforcement, fully encapsulated			
Flat seal material	Fluororubber 75 FPM 4100			
Dimensions	42 x 25 x 12			mm
Weight (incl. 10 m cable)	0.3			kg
Ambient temperature	-25	-	+50	°C
Degree of protection	IP67/IP69K			
Installation orientation	Any			
Method of operation	Inductive			
Power supply	Via evaluation unit			
<b>In combination with actuator CES-A-BCA</b>				
Assured release distance $S_{ar}$	-	-	26	mm
Actuating range for center offset $m = 0$ <sup>1)</sup>				
- Switch-on distance	-	15	-	
- Assured switch-on distance $S_{ao}$	10	-	-	
- Switching hysteresis	0.5	2	-	
Minimum distance $s$ for side approach direction	3	-	-	
<b>In combination with actuator CES-A-BDA-20</b>				
Assured release distance $S_{ar}$	-	-	33	mm
Actuating range for center offset $m = 0$ <sup>2)</sup>				
- Switch-on distance	-	16	-	
- Assured switch-on distance $S_{ao}$	11	-	-	
- Switching hysteresis	0.5	2	-	
Minimum distance $s$ for side approach direction	4	-	-	
<b>In combination with actuator CES-A-BDA-18</b>				
Assured release distance $S_{ar}$	-	-	32	mm
Actuating range for center offset $m = 0$ <sup>1)</sup>				
- Switch-on distance	-	16	-	
- Assured switch-on distance $S_{ao}$	10	-	-	
- Switching hysteresis	0.5	1.4	-	
Minimum distance $s$ for side approach direction	5	-	-	
Connecting cable	Hard-wired encapsulated connection cable, with crimped ferrules PVC, $\varnothing$ 4.6 mm			
Cable length	-	-	25	m

- 1) These values apply to surface installation of the read head and the actuator.  
2) These values apply to non-metallic surrounding material. Other materials on request.

## 11.9. Read head CES-A-LQA-SC

- Cube-shaped design 50 x 50 mm
- M8 plug connector

Approvals



### Dimension drawing

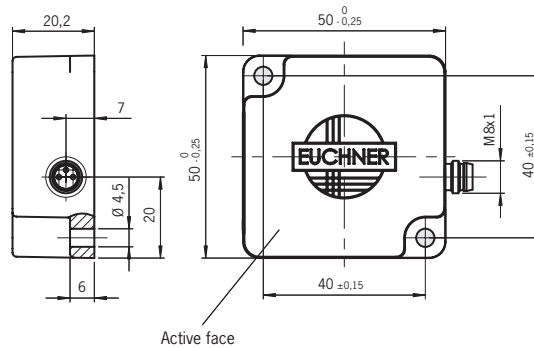

### Typical actuating range

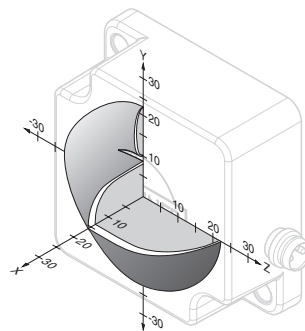

With actuator CES-ABBA or CES-BCA

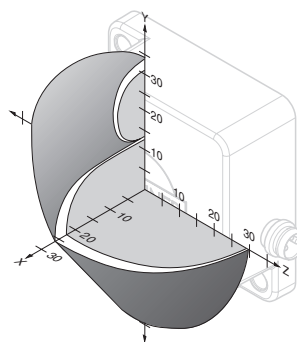

With actuator CES-ABQA on evaluation unit CES-AZ...01B

## Terminal assignment

Read head with connection cable

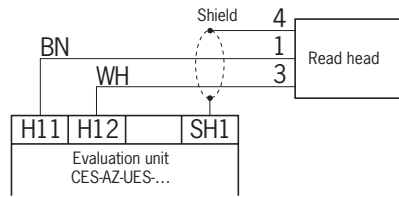

## Technical data

Parameter	Value			Unit
	min.	typ.	max.	
Housing material	Fortron, reinforced thermoplastic, fully encapsulated			
Dimensions	50 x 50 x 20.2			mm
Weight	0.08			kg
Ambient temperature	-25	-	+70	°C
Degree of protection	IP67			
Installation orientation	Any			
Method of operation	Inductive			
Power supply	Via evaluation unit			
<b>In combination with actuator CES-A-BBA or CES-A-BCA</b>				
Assured release distance $S_{ar}$	-	-	47	mm
Actuating range for center offset $m = 0$ <sup>1)</sup>				
- Switch-on distance	-	15	-	
- Assured switch-on distance $S_{a0}$	10	-	-	
- Switching hysteresis	2	3	-	
<b>In combination with actuator CES-A-BQA on evaluation unit CES-AZ-...-01B</b>				
Assured release distance $S_{ar}$	-	-	60	mm
Actuating range with vertical approach direction				
Center offset $m = 0$ <sup>1)</sup>				
- Switch-on distance	-	23	-	
- Assured switch-on distance $S_{a0}$	16	-	-	
- Switching hysteresis	2	3	-	
Actuating range with side approach direction				
Distance in x direction = 10 mm				
- Switch-on distance	-	28	-	
- Assured switch-on distance $S_{a0}$	24	-	-	
- Switching hysteresis	1	1.3	-	
Connecting cable	-	-	25	m

1) These values apply to surface installation of the read head and the actuator.

### 11.10. Read head CES-A-LMN-SC

- Cylindrical design M12
- M8 plug connector

#### Approvals



#### Dimension drawing

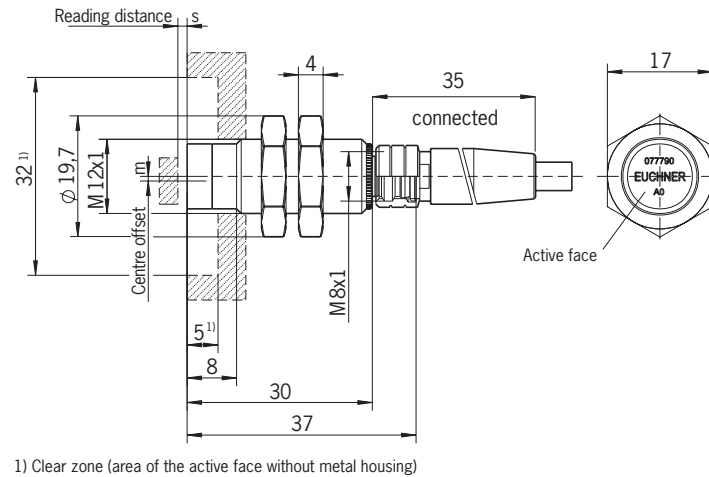

1) Clear zone (area of the active face without metal housing)



#### NOTICE

The read head is allowed to be installed as a maximum up to the clear zone (area of the active face without metal housing).

#### Typical actuating range

With evaluation unit CES-AZ-UES-... and actuator CES-A-BMB

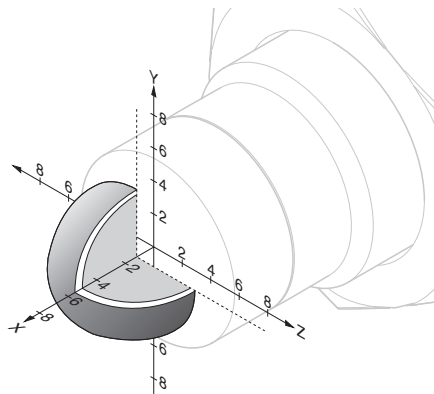

#### NOTICE

A minimum distance of  $s = 1.2$  mm must be maintained.

## Terminal assignment

Read head with plug connector

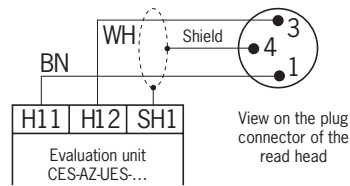

## Technical data

Parameter	Value			Unit
	min.	typ.	max.	
Housing material	Nickel-plated CuZn housing sleeve Plastic PBT GF20 cap			
Dimensions	M12 x 1, length 38			mm
Weight (incl. 10 m cable)	0.2			kg
Ambient temperature	-25	-	+85	°C
Ambient pressure (only of active face in installed condition)	-	-	10	bar
Degree of protection	IP67/IP69/IP69K			
Installation orientation	Any			
Method of operation	Inductive			
Power supply	Via evaluation unit			
Connection	M8 plug connector, 3-pin			
Connecting cable	-	-	15	m
<b>In combination with actuator CES-A-BMB</b>				
Assured release distance $S_{ar}$	-	-	10	mm
Actuating range for center offset $m = 0$ <sup>1)</sup>				
- Switch-on distance	-	5	-	
- Assured switch-on distance $S_{ao}$	3.5	-	-	
- Switching hysteresis	0.1	0.3	-	
<b>In combination with actuator CES-A-BDA-20</b>				
Assured release distance $S_{ar}$	-	-	26	mm
Actuating range for center offset $m = 0$ <sup>1)</sup>				
- Switch-on distance <sup>2)</sup>	-	9	-	
- Assured switch-on distance $S_{ao}$	6	-	-	
- Switching hysteresis	1	1.8	-	
<b>In combination with actuator CES-A-BDA-18</b>				
Assured release distance $S_{ar}$	-	-	21	mm
Actuating range for center offset $m = 0$ <sup>1)</sup>				
- Switch-on distance <sup>3)</sup>	-	9	-	
- Assured switch-on distance $S_{ao}$	6	-	-	
- Switching hysteresis	0.5	1	-	
<b>In combination with actuator CES-A-BBA</b>				
Assured release distance $S_{ar}$	-	-	25	mm
Actuating range for center offset $m = 0$ <sup>1)</sup>				
- Switch-on distance <sup>3)</sup>	-	8	-	
- Assured switch-on distance $S_{ao}$	5	-	-	
- Switching hysteresis	1	1.83	-	

- 1) These values apply to surface installation of the read head in steel.
- 2) A distance of  $s = 4$  mm must be maintained for a side approach direction.
- 3) A distance of  $s = 3$  mm must be maintained for a side approach direction.

### 11.11. Actuator CES-A-BBN

- › Cube-shaped design 42 x 25 mm
- › Attachment compatible with series CES-A-LNA/LCA

#### Dimension drawing for CES-A-BBN

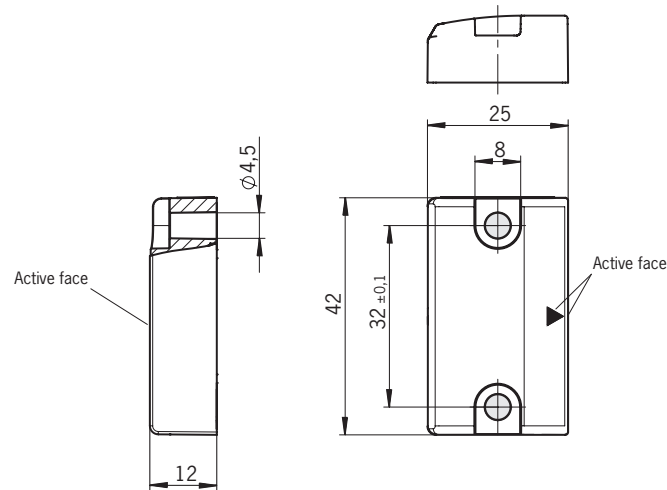

#### Technical data

Parameter	Value			Unit
	min.	typ.	max.	
Housing material	Reinforced thermoplastic (PBT), fully encapsulated			
Dimensions	42 x 45 x 12			mm
Weight	0.025			kg
Ambient temperature	-25	-	+70	°C
Degree of protection	IP67			
Installation orientation	Active face opposite read head			
Power supply	Inductive via read head			



## 11.12. Actuator CES-A-BSP

› Optimized for aluminum profile mounting

### Dimension drawing for CES-A-BSP

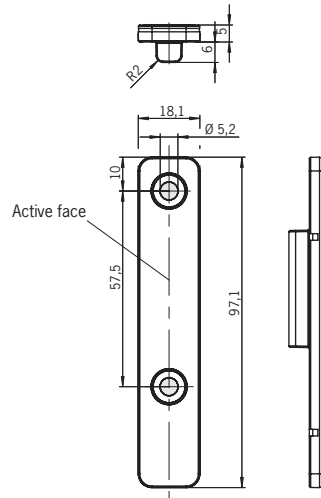

### Technical data

Parameter	Value			Unit
	min.	typ.	max.	
Housing material	PA6 GF30			
Weight	0.02			kg
Ambient temperature	-25	-	+70	°C
Degree of protection	IP67			
Installation orientation	Active face opposite read head			
Power supply	Inductive via read head			

### 11.13. Actuator CES-A-BDN-06

▸ Cylindrical design  $\varnothing$  6 mm

#### Dimension drawing for CES-A-BDN-06

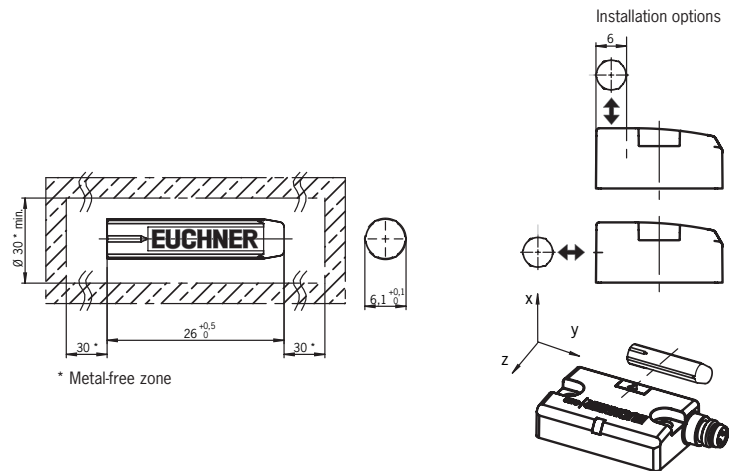

#### Technical data

Parameter	Value			Unit
	min.	typ.	max.	
Housing material	Macromelt PA-based plastic			
Dimensions	26 x $\varnothing$ 6			mm
Weight	0.005			kg
Ambient temperature	-25	-	+70	°C
Degree of protection	IP67			
Installation orientation	Active face opposite read head			
Power supply	Inductive via read head			

## 11.14. Actuator CES-A-BBA/CES-A-BCA

- › Cube-shaped design 42 x 25 mm
- › CES-A-BCA suitable for use in aggressive media (e.g. acids, alkalis)
- › In combination with read head CES-A-LNA.../CES-A-LCA...

### Dimension drawing for CES-A-BBA

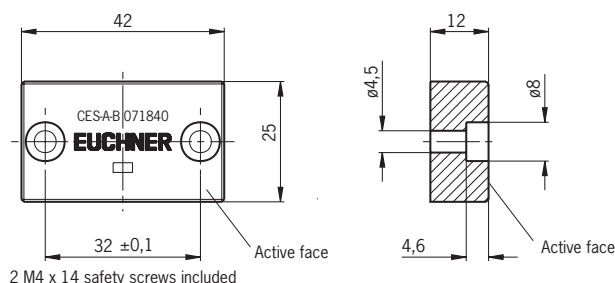

### Dimension drawing for CES-A-BCA

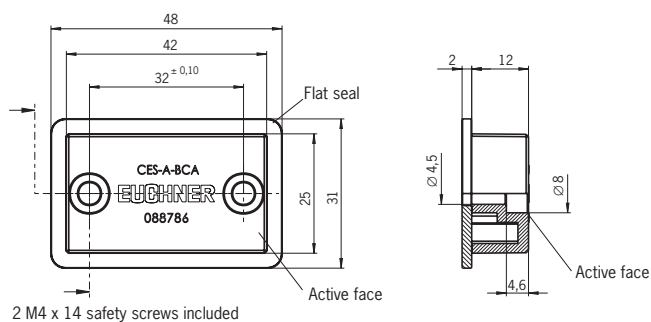

### NOTICE

CES-A-BCA: The flat seal provided must be used during assembly.

### Technical data

Parameter	Value			Unit
	min.	typ.	max.	
Housing material	Fortron, reinforced thermoplastic, fully encapsulated			
- CES-A-BBA	PE-HD plastic without reinforcement, fully encapsulated			
- CES-A-BCA	Fluororubber 75 FPM 4100			
Flat seal material (CES-A-BCA only)				
Dimensions	42 x 25 x 12			mm
Weight	0.02			kg
Ambient temperature				
- CES-A-BBA	-25	-	+70	°C
- CES-A-BCA	-25	-	+50	
Degree of protection	IP67/IP69K			
Installation orientation	Active face opposite read head			
Power supply	Inductive via read head			

### 11.15. Actuator CES-A-BQA

▸ Cube-shaped design 50 x 50 mm

#### Dimension drawing for CES-A-BQA

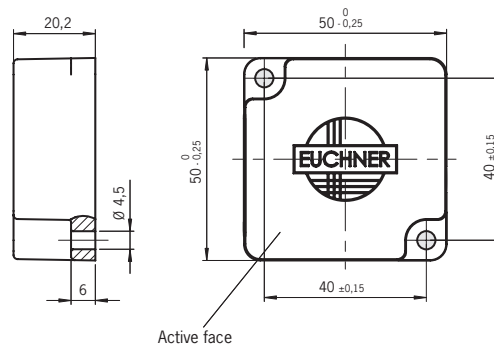

#### Technical data

Parameter	Value			Unit
	min.	typ.	max.	
Housing material	Fortron, reinforced thermoplastic, fully encapsulated			
Dimensions	50 x 50 x 20.2			mm
Weight	0.07			kg
Ambient temperature	-25	-	+70	°C
Degree of protection	IP67			
Installation orientation	Active face opposite read head			
Power supply	Inductive via read head			

## 11.16. Actuator CES-A-BDA-20

- › Round design  $\varnothing$  20 mm
- › In combination with read head CES-A-LNA.../CES-A-LCA...

### Dimension drawing

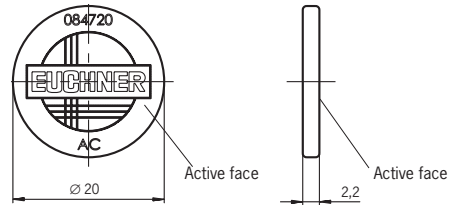

### Technical data

Parameter	Value			Unit
	min.	typ.	max.	
Housing material		PC plastic		
Dimensions		$\varnothing$ 20 x 2.2		mm
Weight		0.0008		kg
Ambient temperature	-25	-	+70	°C
Degree of protection		IP67		
Installation orientation		Active face opposite read head		
Power supply		Inductive via read head		

### 11.17. Actuator CES-A-BDA-18

- Round design  $\varnothing$  18 mm
- In combination with read head CES-A-LNA.../CES-A-LCA...

#### Dimension drawing

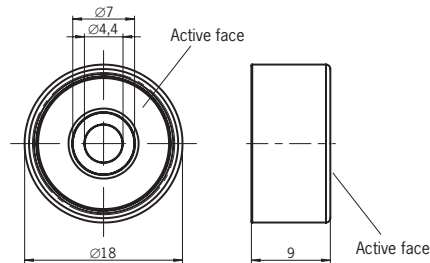

#### Technical data

Parameter	Value			Unit
	min.	typ.	max.	
Housing material - Sleeve - Active face	PBT-GF30, thermoplastic plastic PEEK 450, thermoplastic plastic			
Fixing screw tightening torque	2			Nm
Dimensions	$\varnothing$ 18 x 9			mm
Weight	0.003			kg
Ambient temperature	-25	-	+70	$^{\circ}$ C
Degree of protection	IP65/IP67			
Installation orientation	Active face opposite read head			
Power supply	Inductive via read head			

## 11.18. Actuator CES-A-BMB

- Cylindrical design M12 x 75
- In combination with read head CES-A-LMN-SC  
(actuating range on request for read head CES-A-LNA.../LCA...)

### Dimension drawing

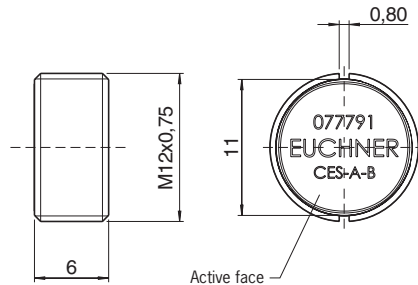

### NOTICE

- The actuator can be screwed into the M12 x 0.75 thread provided with the aid of an insertion tool (order no. 037 662).
- Flush installation of the actuator in steel is permissible.

### Technical data

Parameter	Value			Unit
	min.	typ.	max.	
Housing material	Stainless steel			
Dimensions	M12 x 0.75, depth 6			mm
Weight	0.002			kg
Ambient temperature	-25	-	+85	°C
Degree of protection	IP67/IP69/IP69K			
Installation orientation	Active face opposite read head			
Power supply	Inductive via read head			

## 12. Ordering information and accessories



**Tip!**

Suitable accessories, e.g. cables or assembly material, can be found at [www.euchner.com](http://www.euchner.com). To order, enter the order number of your item in the search box and open the item view. Accessories that can be combined with the item are listed in "Accessories."

## 13. Inspection and service



**WARNING**

Loss of the safety function because of damage to the device.  
In case of damage, the related safety component must be replaced. The replacement of individual parts in a safety component is not permitted.

Regular inspection of the following is necessary to ensure trouble-free long-term operation:

- › Check the switching function (see chapter 9.3. *Functional check on page 18*)
- › Check the secure mounting of the devices and the connections
- › Check for soiling
- › Check for sealing of the plug connector on the safety switch
- › Check for loose cable connections on the plug connector
- › Check the release distance

No servicing is required. Repairs to the device are only allowed to be made by the manufacturer.



**NOTICE**

The year of manufacture can be seen in the lower right corner of the rating plate.

## 14. Service

If servicing is required, please contact:

EUCHNER GmbH + Co. KG  
Kohlhammerstraße 16  
70771 Leinfelden-Echterdingen

**Service telephone:**

+49 711 7597-500

**E-mail:**

[support@euchner.de](mailto:support@euchner.de)

**Internet:**

[www.euchner.com](http://www.euchner.com)



## 15. Declaration of conformity



# EUCHNER

More than safety.

**EU-Konformitätserklärung**  
**EU declaration of conformity**  
**Déclaration UE de conformité**  
**Dichiarazione di conformità UE**  
**Declaración UE de conformidad**

Original DE  
Translation EN  
Traduction FR  
Traduzione IT  
Traducción ES

2077154-35-12/18

Die nachfolgend aufgeführten Produkte sind konform mit den Anforderungen der folgenden Richtlinien (falls zutreffend):  
The beneath listed products are in conformity with the requirements of the following directives (if applicable):  
Les produits mentionnés ci-dessous sont conformes aux exigences imposées par les directives suivantes (si valable)  
I prodotti sotto elencati sono conformi alle direttive sotto riportate (dove applicabili):  
Los productos listados a continuación son conforme a los requisitos de las siguientes directivas (si fueran aplicables):

I:	Maschinenrichtlinie	2006/42/EG
	Machinery directive	2006/42/EC
	Directive Machines	2006/42/CE
	Direttiva Macchine	2006/42/CE
II:	Funkanlagen-Richtlinie (RED)	2014/53/EU
	Radio equipment directive	2014/53/EU
	Directive équipement radioélectrique	2014/53/UE
	Direttiva apparecchiatura radio	2014/53/UE
III:	RoHS Richtlinie	2011/65/EU
	RoHS directive	2011/65/EU
	Directive de RoHS	2011/65/UE
	Direttiva RoHS	2011/65/UE
	Direttiva RoHS	2011/65/UE

Die Schutzziele der Niederspannungsrichtlinie 2014/35/EU und EMV Richtlinie 2014/30/EU werden gemäß Artikel 3.1 der Funkanlagen-Richtlinie eingehalten.

The safety objectives of the Low-voltage directive 2014/35/EU and EMC Directive 2014/30/EU comply with article 3.1 of the Radio equipment directive.

Les objectifs de sécurité de la Directive basse tension 2014/35/UE et Directive de CEM 2014/30/UE sont conformes à l'article 3.1 de la Directive équipement radioélectrique.

Gli obiettivi di sicurezza della Direttiva bassa tensione 2014/35/UE e Direttiva CEM 2014/30/UE sono conformi a quanto riportato nell'articolo 3.1 della Direttiva apparecchiatura radio.

Los objetivos de seguridad de la Directiva de bajo voltaje 2014/35/UE y Directiva CEM 2014/30/UE cumplen con el artículo 3.1 de la Directiva equipo radioeléctrico.

Folgende Normen sind angewandt:

Following standards are used:

Les normes suivantes sont appliquées:

Vengono applicate le seguenti norme:

Se utilizan los siguientes estándares:

a:	EN 60947-5-3:2013
b:	EN ISO 14119:2013
c:	EN 62026-2:2013 (ASi)
d:	EN ISO 13849-1:2015
e:	EN ISO 13849-2:2012
f:	EN 60947-5-2:2007/A1:2012
i:	EN 50581:2012 (RoHS)
j:	EN 50364:2010
k:	EN 300 330 V2.1.1



**EUCHNER**

More than safety.

Bezeichnung der Bauteile Description of components Description des composants Descrizione dei componenti Descripción de componentes	Type Type Type Tipo Tipo	Richtlinie Directives Directive Direttiva Directivas	Normen Standards Normes Norme Estándares	Zertifikats-Nr. No. of certificate Número du certificat Numero del certificato Número del certificado						
Auswertegerät Safety Unit Analyseur Centralina Unidad de evaluación	CES-A-ABA-01 CES-A-UBA-01 CES-A-ABA-01B CES-A-UBA-01B	I, II, III	a, b, d, e, i, j, k	ET 15038						
	CES-A-AEA-02B CES-A-AEA-04B CES-A-UEA-02B CES-A-UEA-04B				I, II, III	a, b, d, e, i, j, k	ET 15050			
	CES-AZ-ABS-01B CES-AZ-UBS-01B							I, II, III	a, b, d, e, i, j, k	ET 15038
	CES-AZ-AES-01B CES-AZ-AES-02B CES-AZ-AES-04B CES-AZ-UES-01B CES-AZ-UES-02B CES-AZ-UES-04B									
	Lesekopf Read head Tête de lecture Testina di lettura Cabeza lectora	CES-A-LMN-SC CES-A-LNA-SC CES-A-LNA-xxx CES-A-LCA-xxx CES-A-LQA-SC CES-A-LNN-SC CES-A-LNN-V-...	I, II, III	a, b, d, e, i, j, k				ET 15038		
					ET 15050					
					ET 15042					
		CES-A-LSP-SB CES-A-LSP-...			I, II, III	a, b, d, e, i, j, k	ET 15042			
		CEM-A-LE05K-S2 CEM-A-LE05R-S2 CEM-A-LH10K-S3 CEM-A-LH10R-S3 CEM-A-LE05K-S1-10V CEM-A-LH10K-S2-10V						I, II, III	a, b, d, e, i, j, k	ET 15038
					ET 15050					
		ET 15042								
	CET-AX-L...	I, II, III	a, b, d, e, i, j, k	ET 13050						
Betätiger Actuator Actionneur Azionatore Actuador	CES-A-BBA... CES-A-BCA... CES-A-BDA... CES-A-BMB... CES-A-BQA...				I, II, III	a, b, d, e, i, j, k	ET 15038			
		ET 15050								
	CES-A-BSP... CES-A-BBN...	I, II, III	a, b, d, e, i, j, k	ET 15042						
	CEM-A-BE05 CEM-A-BH10			I, II, III	a, b, d, e, i, j, k	ET 15038				
						ET 15050				
				ET 15042						
	CET-A-BW...	I, II, III	a, b, d, e, i, j, k	ET 13050						

Benannte Stelle  
Notified Body  
Organisme notifié  
Sede indicata  
Entidad citada

0340  
DGVU Test Prüf- und Zertifizierungsstelle Fachausschuss Elektrotechnik  
Gustav-Heinemann-Ufer 130  
50968 Köln - Germany



# EUCHNER

More than safety.

Bezeichnung der Bauteile <i>Description of components</i> <i>Description des composants</i> <i>Descrizione dei componenti</i> <i>Descripción de componentes</i>	Type <i>Type</i> <i>Type</i> <i>Tipo</i> <i>Typo</i>	Richtlinie <i>Directives</i> <i>Directive</i> <i>Direttiva</i> <i>Directivas</i>	Normen <i>Standards</i> <i>Normes</i> <i>Norma</i> <i>Estándares</i>	Zertifikats-Nr. <i>No. of certificate</i> <i>Numéro du certificat</i> <i>Numero del certificato</i> <i>Número del certificado</i>
Auswertegerät <i>Safety Unit</i> <i>Analyseur</i> <i>Centralina</i> <i>Unidad de evaluación</i>	CES-AZ-ALS... CES-A-F1B-01B-AS1 CES-A-V1B-01B-AS1 CEM-A-ME05K-S1 CEM-A-LE05H-S2 CEM-A-LE05K-S2-P  CET1-AX-L... CET2-AX-L...	I, II, III I, II, III I, II, III I, II, III I, II, III I, II, III	a, b, d, e, i, j, k a, b, c, d, e, i, j, k a, b, d, e, i, j, k a, b, d, e, i, j, k a, b, d, e, i, j, k	UQS 115948 Euchner QS PB 62/2005 Euchner QS PB 22/2005 Euchner QS PB 132/2010 Euchner QS PB 019/2018 Euchner QS PB 17/2008 Euchner QS PB 23/2008 Euchner QS PB 116/2009 Euchner QS PB 115/2009
Lesekopf <i>Read head</i> <i>Tête de lecture</i> <i>Testina di lettura</i> <i>Cabeza lectora</i>	CES-A-LFP...	I, II, III	a, b, d, e, i, j, k	Euchner QS PB 110/2010
Betätiger <i>Actuator</i> <i>Actionneur</i> <i>Azionatore</i> <i>Actuador</i>	CES-A-BFP...	I, II, III	a, b, d, e, i, j, k	Euchner QS PB 110/2010
Zubehör <i>Accessory</i> <i>Accessoire</i> <i>Accessorio</i> <i>Accesorio</i>	PM-SCL-096945	III	f, i	Euchner QS PB 14 /2006

Genehmigung der umfassenden Qualitätssicherung (UQS) durch die benannte Stelle  
*Approval of the full quality assurance system by the notified body*  
*Approbation du système d'assurance qualité complet par l'organisme notifié*  
*Approvazione del sistema di garanzia di qualità totale da parte dell'organismo notificato*  
*Aprobación del sistema de aseguramiento de calidad total por parte del organismo notificado*

0035  
TÜV Rheinland  
Industrie Service GmbH  
Alboinstr. 56 - 12103 Berlin  
Germany

Die alleinige Verantwortung für die Ausstellung dieser Konformitätserklärung trägt der Hersteller:  
*This declaration of conformity is issued under the sole responsibility of the manufacturer:*  
*La présente déclaration de conformité est établie sous la seule responsabilité du fabricant:*  
*La presente dichiarazione di conformità è rilasciata sotto la responsabilità esclusiva del fabbricante:*  
*La presente declaración de conformidad se expide bajo la exclusiva responsabilidad del fabricante:*

EUCHNER GmbH + Co. KG  
Kohlhammerstraße 16  
70771 Leinfelden-Echterdingen  
Germany

Leinfelden, Dezember 2018  
EUCHNER GmbH + Co. KG  
Kohlhammerstraße 16  
70771 Leinfelden-Echterdingen  
Germany

i.A. Dipl.-Ing. Richard Holz  
Leiter Elektronik-Entwicklung  
*Manager Electronic Development*  
*Responsable Développement Électronique*  
*Direttore Sviluppo Elettronica*  
*Director de desarrollo electrónico*

i.A. Dipl.-Ing. (FH) Duc Binh Nguyen  
Dokumentationsbevollmächtigter  
*Documentation manager*  
*Responsable documentation*  
*Responsabilità della documentazione*  
*Agente documenta*

EUCHNER GmbH + Co. KG  
Kohlhammerstraße 16  
70771 Leinfelden-Echterdingen  
info@euchner.de  
www.euchner.com

Edition:  
2105274-13-07/21  
Title:  
Operating instructions Non-Contact Safety System  
CES-AZ-UES-... (Multicode)  
(Translation of the original operating instructions)  
Copyright:  
© EUCHNER GmbH + Co. KG, 07/2021

Subject to technical modifications; no responsibility is accepted for the accuracy of this information.